

# ***MLT6SKDS***

## *Light Tower Parts Manual*

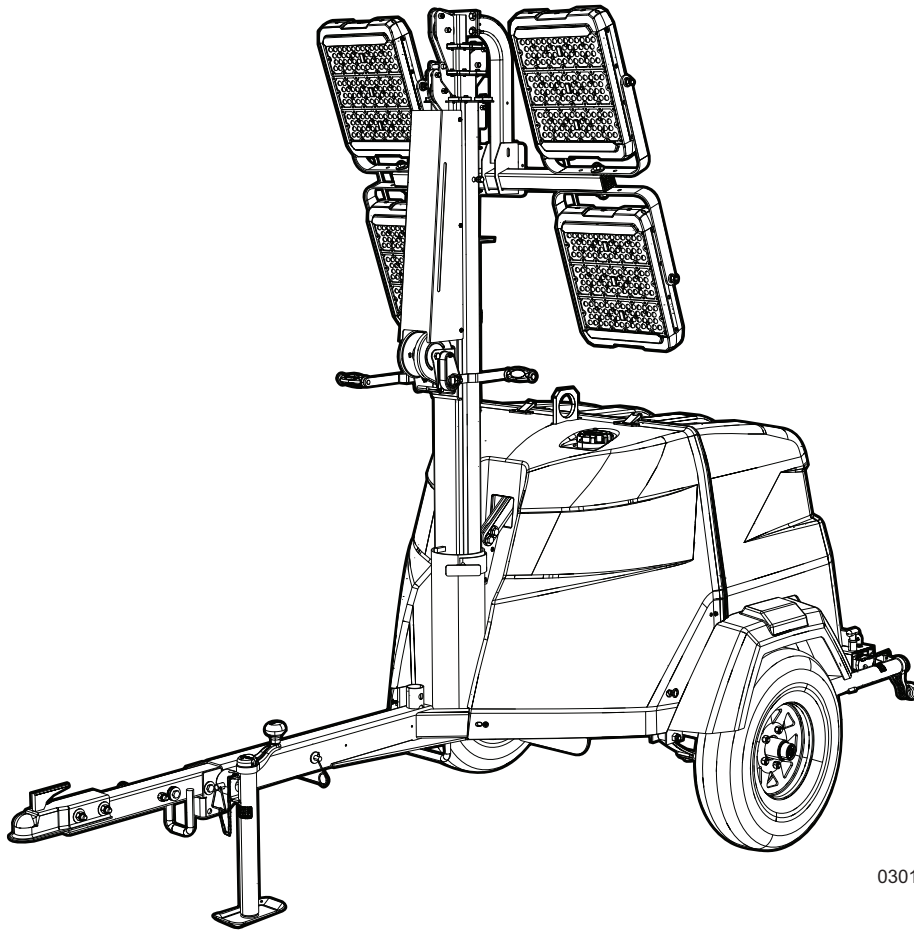

03019

MODEL NUMBER: \_\_\_\_\_

SERIAL NUMBER: \_\_\_\_\_

DATE PURCHASED: \_\_\_\_\_

***SAVE THIS MANUAL FOR FUTURE REFERENCE***

 **WARNING**

**CANCER AND REPRODUCTIVE HARM**

[www.P65Warnings.ca.gov](http://www.P65Warnings.ca.gov)

(000393a)

 **WARNING**

Breathing diesel engine exhaust exposes you to chemicals known to the State of California to cause cancer and birth defects or other reproductive harm.

- Always start and operate the engine in a well-ventilated area.
- If in an enclosed area, vent the exhaust to the outside.
- Do not modify or tamper with the exhaust system.
- Do not idle the engine except as necessary.

For more information go to

[www.P65Warnings.ca.gov/diesel](http://www.P65Warnings.ca.gov/diesel)

(000394)

# Introduction

This parts manual was prepared based on the information available at the time of publication and is subject to change without notice. Generac Mobile reserves the right to change parts at any time. To check whether a revised parts manual is available, contact Generac Mobile.

DO NOT MODIFY or use this equipment for any application other than which it was designed for. To keep your equipment fully operational, it is suggested you maintain a stock of commonly used maintenance or service parts. A recommended spare parts list can be found in the back of this manual. To order service parts, please go to [www.generacmobileproducts.com](http://www.generacmobileproducts.com) or call Generac Mobile.



## **WARNING**

Consult Manual. Read and understand manual completely before using product. Failure to completely understand manual and product could result in death or serious injury. (000100a)

---

## **WARNING**

Environmental Hazard. Always recycle batteries at an official recycling center in accordance with all local laws and regulations. Failure to do so could result in environmental damage, death, or serious injury. (000228)

---

## **GENERAC MOBILE PRODUCTS LLC**

**215 Power Drive • Berlin, WI 54923 U.S.A.**

**Phone: 920-361-4442**

**FAX: 920-361-4416**

**Toll Free: 1-800-926-9768**

**[www.generacmobileproducts.com](http://www.generacmobileproducts.com)**

**For technical or parts QUESTIONS, contact Generac Mobile Technical Service at 1-800-926-9768.**

Engine Make: \_\_\_\_\_

Engine Serial Number: \_\_\_\_\_

Engine Model Number: \_\_\_\_\_

This Page Intentionally Left Blank

## Table of Contents

Introduction .....	iii
Parts Manual Instructions .....	1
Unit Decals - Front, Rear and Top.....	2
Unit Decals - Left and Right Sides.....	4
Unit Decals - Inside Unit.....	6
Mast, Junction Box and Lights to Unit .....	8
Light Assembly - 296 Watt.....	10
Light Assembly - 320 Watt.....	12
Mast Junction Box Assembly - 320 Watt Version.....	14
Mast Junction Box Assembly - 296 Watt Version.....	16
Diffused Lighting 296W (If Equipped).....	18
Diffused Lighting 320W (If Equipped).....	20
Mast Assembly .....	22
Mast Assembly - Bottom Post - Manual Winch .....	24
Mast Assembly - Bottom Post - Electric Winch .....	26
Enclosure Assembly (1 of 2).....	28
Enclosure Assembly (2 of 2).....	30
Control Box Assembly .....	32
Control Box Assembly - Power Zone Option (1 of 2).....	34
Control Box Assembly - Power Zone Option (2 of 2).....	36
Cooling System Assembly.....	38
Engine Assembly (1 of 2) .....	40
Engine Assembly (2 of 2) .....	42
Generator Assembly .....	44
Components to Trailer Assembly .....	46
Trailer Assembly.....	48
Recommended Spare Parts - Engine and Service Kits.....	50
Recommended Spare Parts - Electrical .....	52
Recommended Spare Parts - Misc.....	54



# Parts Manual Instructions

Product illustrations are only representations. Products supplied may vary from the illustrations in this parts manual. Parts not shown in the illustration are indicated by a double dash (--) in the item column.

Please be prepared to provide the following information when ordering replacement parts: model number, serial number (on unit serial tag), part number, purchase order number (if applicable), shipping address, shipping method.

Refer to the illustration below to locate the unit ID tag and Vehicle Identification Number (VIN) tag on the unit. Important information, such as the unit serial number, model number, VIN and tire loading information are found on these tags. Record the information from these tags so it is available if the tags are lost or damaged. When ordering parts or requesting assistance, you may be asked to provide this information.

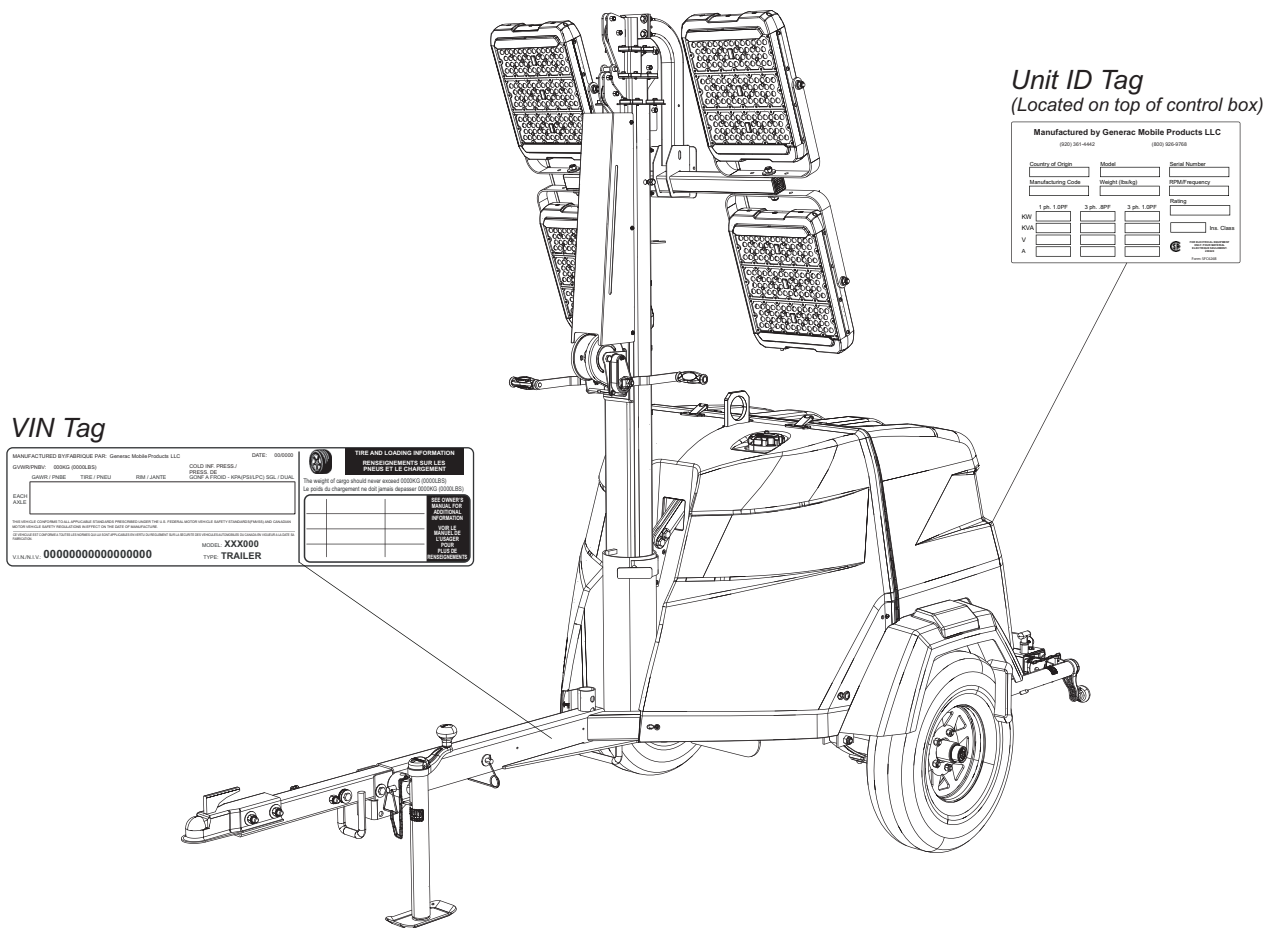

**VIN Tag**

MANUFACTURED BY/FABRIQUE PAR: Genac/Mobile Products LLC		DATE: 05/05/00
GVWR/Poids: 5000kg (11025 lbs)	COULÉ PAR / PRESSÉ PAR: [ ]	
AXES / AXES: [ ]	PIÈCES DE SÉRIE / À TITRE: [ ]	
<p><b>TIRE AND LOADING INFORMATION</b>  <b>PREUS ET LE CHARGEMENT</b></p> <p>The weight of single axles never exceed (05000) (50000 lbs).          Le poids de chargement ne doit jamais dépasser (05000) (50000 lbs).</p>		
<p>SEE CHARTS          REGARDING          ADDITIONAL          INFORMATION.          VOIR LES          CHARTES EN          RAPPORT          POUR PLUS DE          RENSEIGNEMENTS.</p>		
<p>MODEL: <b>XX000</b>          TYPE: <b>TRAILER</b></p>		
<p>VIN/NO. 0000000000000000</p>		

**Unit ID Tag**  
(Located on top of control box)

Manufactured by Genac/Mobile Products LLC			
(0500) (05/05/00)			
Country of Origin	Date	Serial Number	
Manufacturing Code	Weight (lbs/kg)	RPM/Frequency	
1 pin, 1.0MP	2 pin, 20V	3 pin, 1.0MP	Rating
ROW			
ROW			
V			
A			
			Str. Class

03020





## UNIT DECALS - FRONT, REAR AND TOP

---

Item	Part No.	Qty	Description	Notes
1	55016	1	Decal, safety MLT6SMD	
2	10000036934	1	Decal engine operation MLT6SM/KD	
3	10000039507	1	Decal, operation - PZ	
4	A00002688141	1	Decal, towing instructions	

# UNIT DECALS - LEFT AND RIGHT SIDES

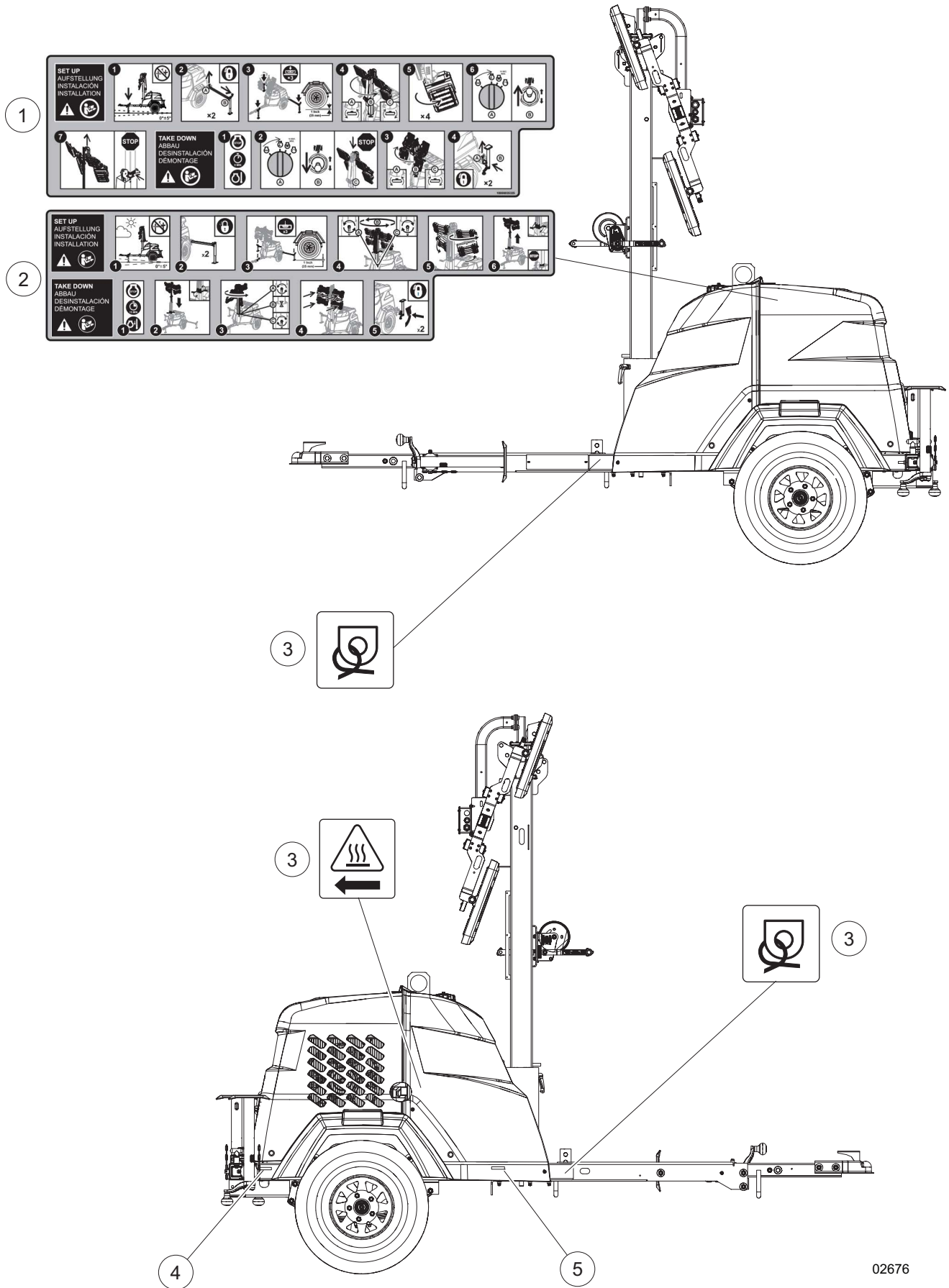

02676

## UNIT DECALS - LEFT AND RIGHT SIDES

---

Item	Part No.	Qty	Description	Notes
1	10000035325	1	Decal, operation MLT6SM - SKDS (electric)	
2	10000035402	1	Decal, operation MLT6SM - SKDS (manual)	shown
3	55016	1	Decal, safety MLT6SMD	
4	72149	1	Reflector, red (4.25 in x .75 in)	Set of two
5	72150	1	Reflector, yellow (4.25 in x .75 in)	Set of two



## UNIT DECALS - INSIDE UNIT

---

Item	Part No.	Qty	Description	Notes
1	55016	1	Decal, safety MLT6SM - SKDS	
2	12142	1	Decal, ground	
3	17986	1	Decal, control panel MLT 6SK-M	
--	70196	1	Decal, control panel - PZ	Powerzone only
4	72132	1	Reflector, rear 2.0 x 2.0 - red	Set of two

# MAST, JUNCTION BOX AND LIGHTS TO UNIT

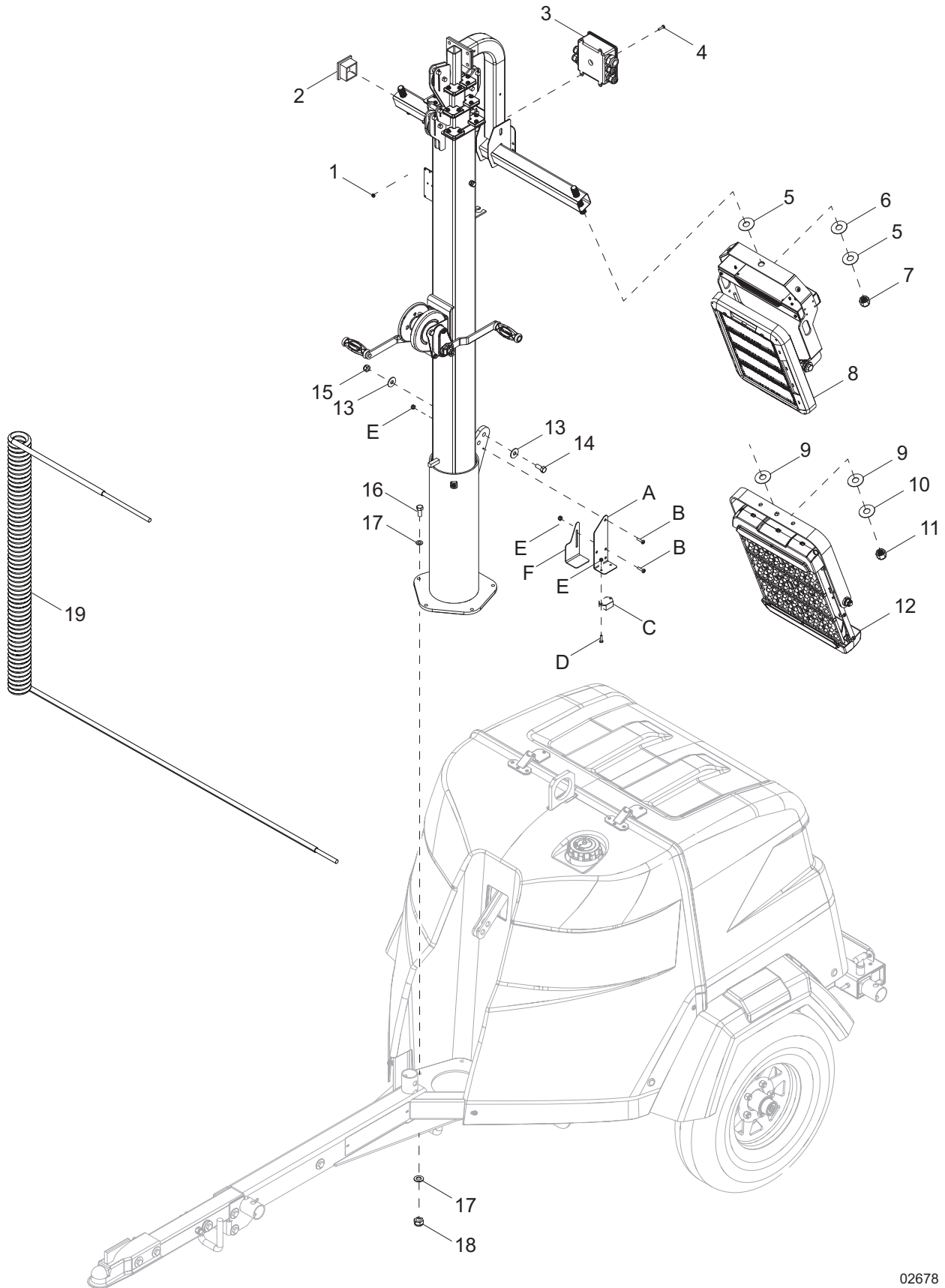

02678

## MAST, JUNCTION BOX AND LIGHTS TO UNIT

Item	Part No.	Qty	Description	Notes
1	60415	4	Nut, 10-32 nylock, SS	
2	10000023259	2	Plug, 2.0 square x .14 ga wall tube, plastic	
3	A0000073922	1	Assembly, mast junction box	296W version
4	60062	4	Screw, 10-32 x .750 pan Phillips, G2	296W version
5	63357	8	Washer, .750 flat 2.0/.062 - plastic	296W version
6	60247	4	Washer, .750 flat 2.020/.130	296W version
7	60308	4	Nut, .750-10 nylock - SS	296W version
8	N/A	4	Assembly, LED light - 4 module, horizontal	call for more info
9	A0000221212	8	Washer, M12 x 37 flat - nylon	320W version
10	G052259	4	Washer, M12 flat	320W version
11	60305	4	Nut, M12-1.75 nylock, G8.8	320W version
12	A0001904532	4	Assembly LED light hardwire 320W	320W version
13	60309	4	Washer, .500 flat 1.060/.090	
14	60484	2	Screw, .500-13 x 2.0 standard hex, G5	
15	60139	5	Screw, .375-16 x 1.50 hex, G5	
16	62221	2	Nut, .500-13 nylock, G5	
17	60386	10	Washer, .375 flat .993/.064	
18	60358	5	Nut, .375-16 nylock, G5	
19	A0000098118	1	Assembly, coil cord w/155 inch tail	320W version
--	39650	1	Assembly, coil cord w/120 inch tail	296W version

*Night Watchman (If equipped):*

A	70208B	1	Bracket, night watchman
B	60488	4	Screw, 8-32 x .750 pan Phillips, G2
C	68763	1	Assembly, night watchman
D	62054	2	Screw, 8-32 x .500 pan Phillips 18-8, SS
E	60270	8	Nut, 8-32 nylock
F	56610B	1	Cover, dusk to dawn sensor

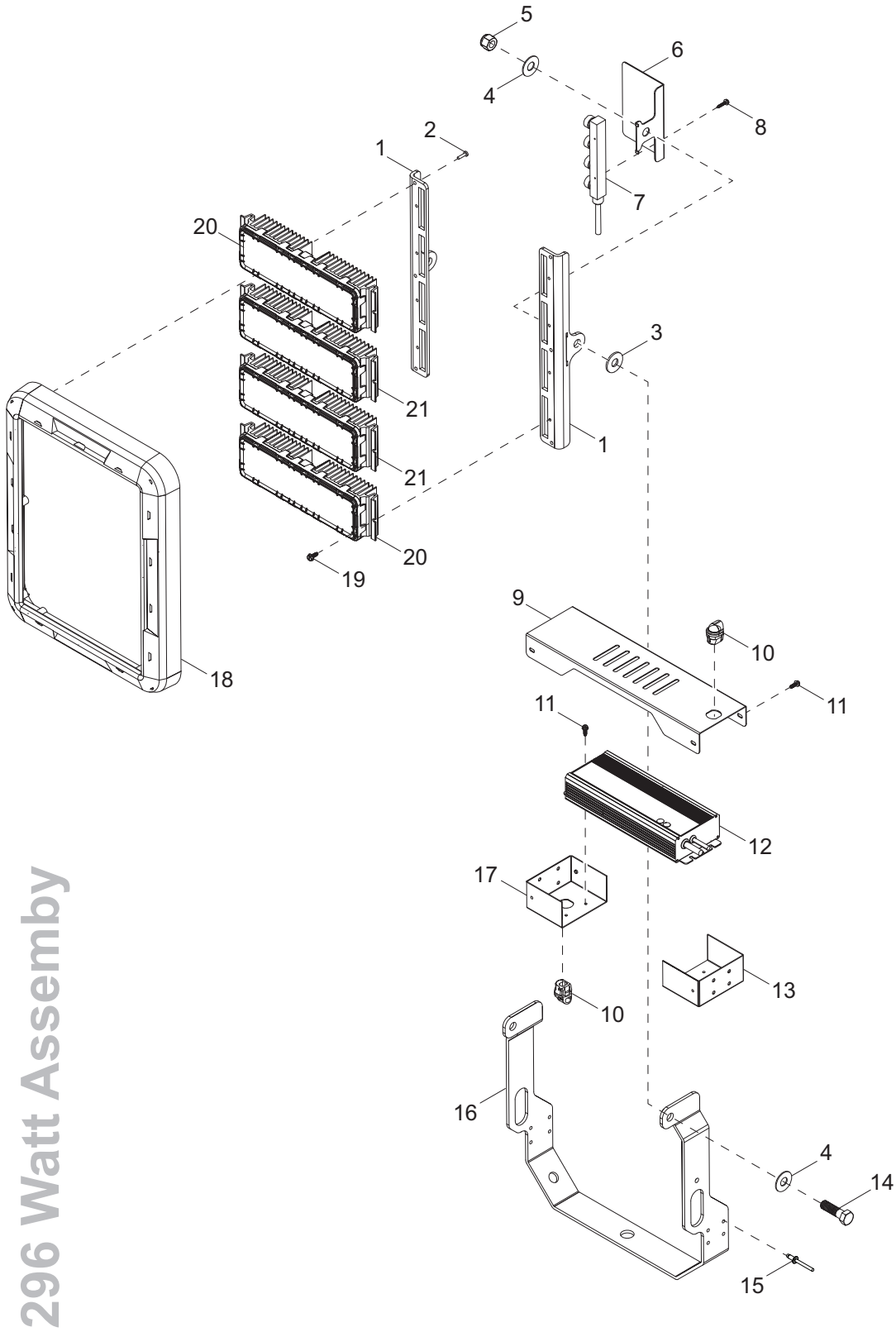

296 Watt Assembly

02880



## LIGHT ASSEMBLY - 296 WATT

Item	Part No.	Qty	Description	Notes
1	10000046102	2	Frame support, LED module - horizontal	
2	10000019163	6	Screw, 8-16 x .625 PLST pan Phillips - black	
3	72134	2	Washer, .500 nylon 1.25/.100	
4	60700	4	Washer, .500 flat 1.250/.060 - SS	
5	62221	2	Nut, .500-13 nylock, G5	
6	10000019164	1	Bracket, connection block	
7	72120	1	Connector block, LED module	
8	73219	2	Screw, #6-20 x .75 sheet metal - SS	
9	10000019153	1	Enclosure, LED driver	
10	10000019152	2	Bushing, strain relief - right angle	
11	10000023706	4	Screw, 8-32 x .500 hex flanged - black	
12	72178	1	Driver, LED 30V 10.7A 321W	
13	10000023684	1	End cap 1, LED driver	
14	62249	2	Screw, .500-13 x 1.250 standard hex - SS	
15	60268	8	Rivet, .188 diameter x .126 to .250 grip	
16	10000023721	1	Trunnion, LED module - horizontal	
17	10000023663	1	End cap 2, LED driver	
18	10000019135	1	End cap, LED module	
19	10000019182	8	Screw, 10-24 x .500 hex flanged	
20	10000019170	2	Module, 60° LED 24-27VDC 60W	
21	10000019160	2	Module, 40° 28 LED 24-27VDC	
--	10000023665	1	Cord, 18/3C, ST00W/SE00W 6.00 w/terminals	
--	10000019079	4	Pigtail, 22-14GA, 3M, 314IDC	

320 Watt Assembly

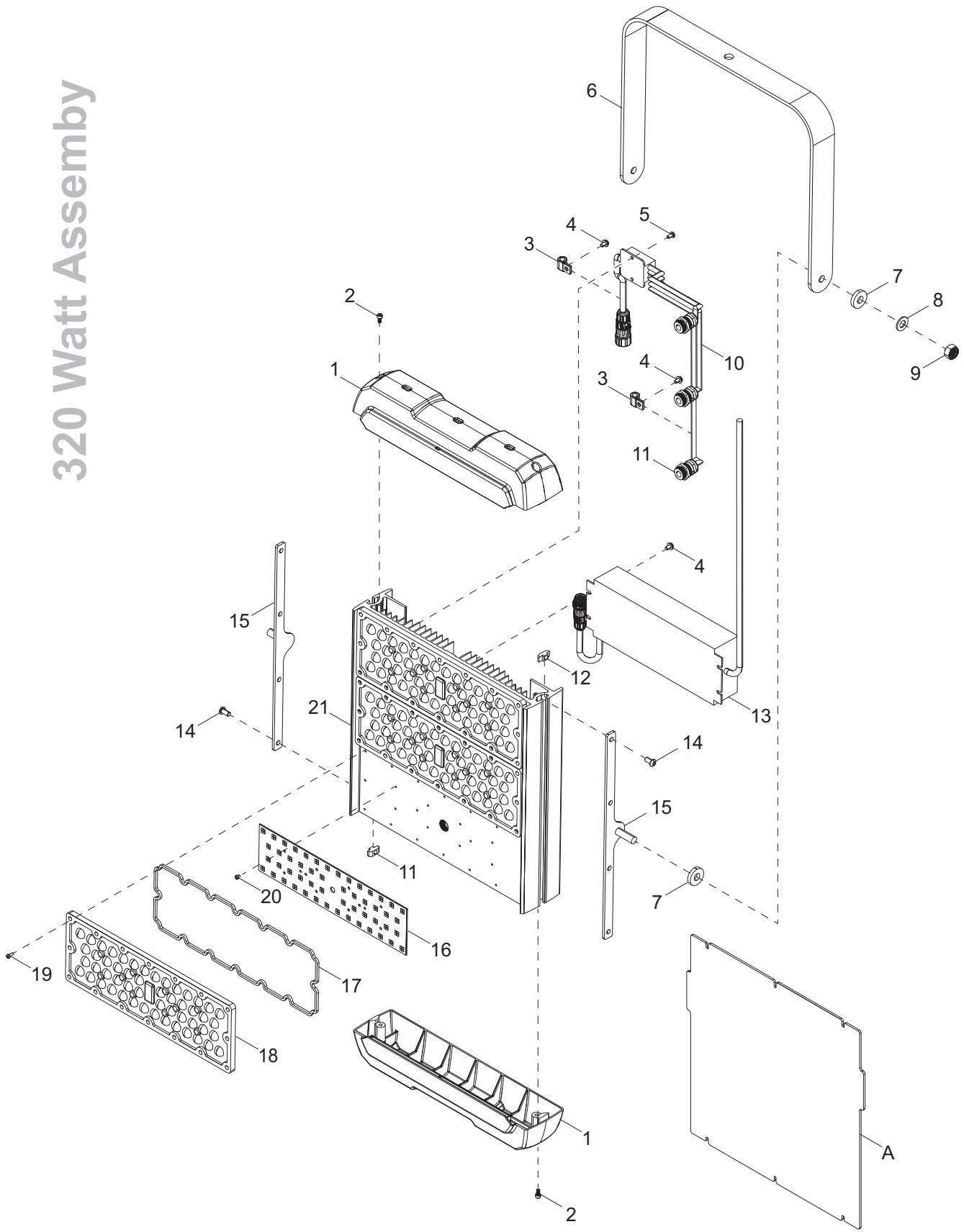

03022

## LIGHT ASSEMBLY - 320 WATT

Item	Part No.	Qty	Description	Notes
1	A0000092362	2	End cap, with diffuser slot	
2	A0000188756	4	Screw, M4-.7 x 12	
3	G020151	2	Clamp, .312 x .302 - steel/vinyl	
4	0G7070	6	Screw, M4-.7 x 14 PPHM	
5	G020745	2	Screw, M4-.7 x 12 PPHM	
6	A0000188712	1	Bracket, trunnion - 320W	
7	A0000188752	4	Washer, M10 ID x 25MM OD x 5 MM T	
8	60027	2	Washer, M10 flat	
9	A0000009451	2	Nut, M10-1.50 nylock, G8.8	
10	A0000188731	1	Cable, 2 position, 3 way splitter - parallel	
11	A0000092266	3	Strain relief, 320W LED	
12	A0000188739	8	Nut, M6-1.00 x 12 hammer	
13	A0000188779	1	Assembly, driver with connector	
14	A0000214354	8	Screw, M6-1.0 x 12 BHSC - black	
15	A0000095202	2	Bracket, trunnion to frame	
16	A0000092359	3	LED, PCB populated 3030	
17	A0000092361	3	Gasket, optical lens seal	
18	A0000092360	3	Lens, optical 60°	
19	A0000192578	48	Screw, mounting - optical lens	
20	A0000192575	30	Screw, mounting - PCB	
21	A0000092179	1	Frame, heat sink 320W - LED	

*Diffused Lighting (If equipped):*

A	A0000095669	1	Kit, diffuser lens 320W - LED
--	A0000277071	1	Kit, diffuser lens storage 320W - LED

# MAST JUNCTION BOX ASSEMBLY - 320 WATT VERSION

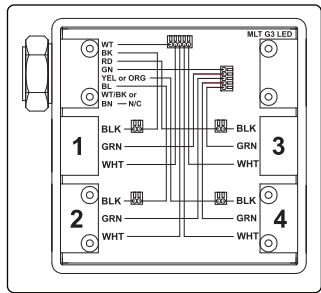

Inside cover

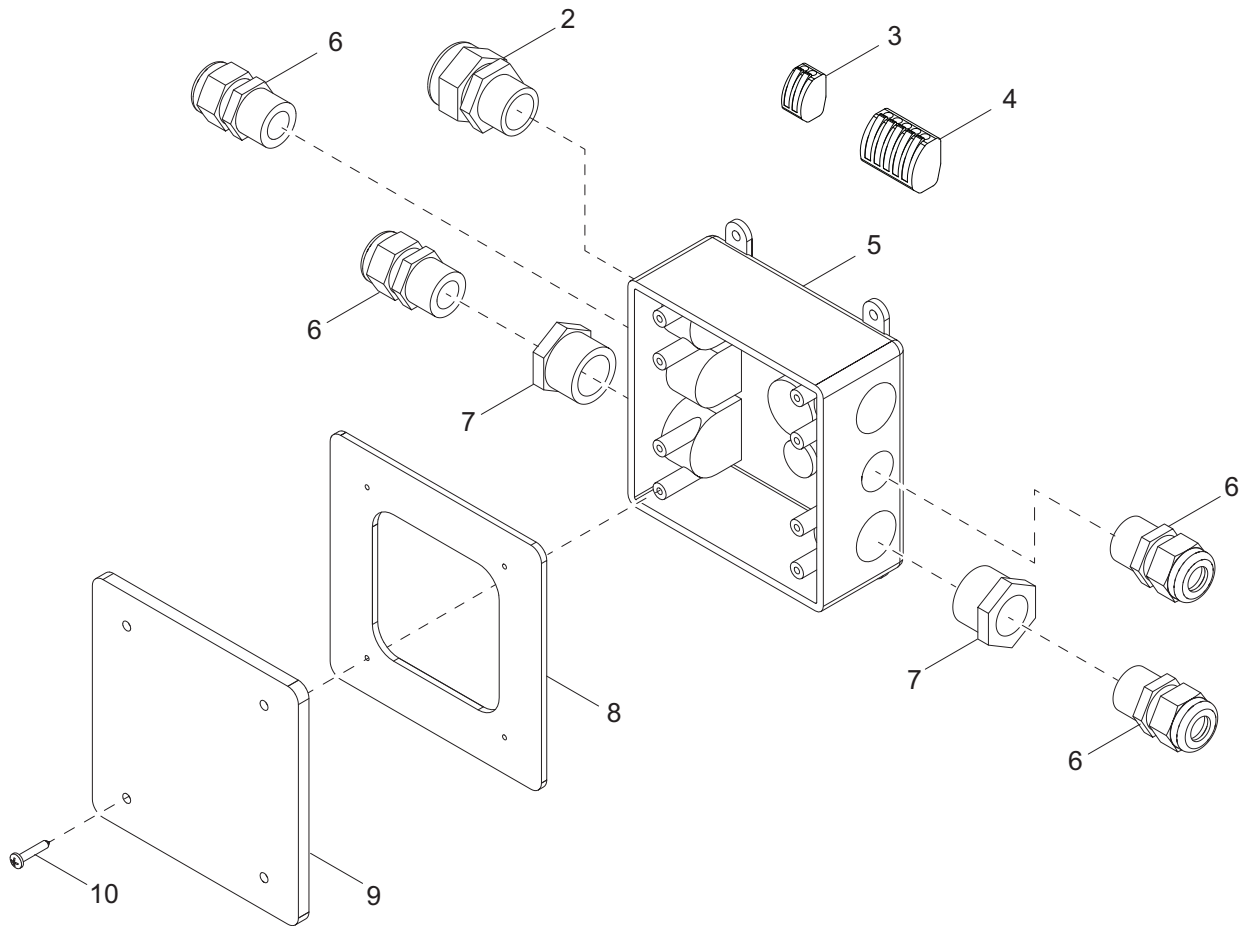
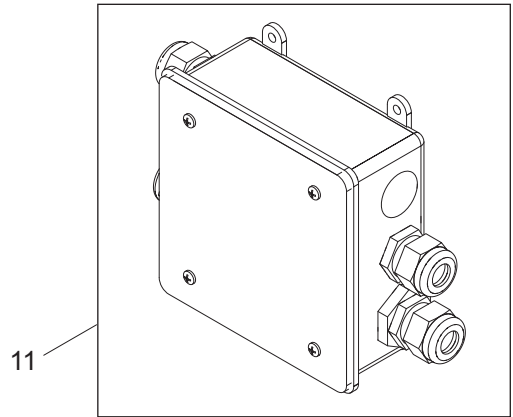

02679

## MAST JUNCTION BOX ASSEMBLY 320 WATT VERSION

Item	Part No.	Qty	Description	Notes
1	10000034314	1	Decal, mast junction box wiring	
2	14656	1	Strain relief, .750NPT water tight	
3	66100	4	Connector, 2 position.	
4	66102	2	Connector, 5 position.	
5	12094	1	Box, junction	
6	15864	4	Strain relief, .500NPT water tight	
7	60755	2	Fitting, strt .750MNPT x .500FNPT, nylon	
8	13749SRV	1	Gasket, junction box - HFI 281000	
9	12109	1	Cover, box, 2-gang plastic	
10	60424	4	Screw, 6-32 x .750 pan Phillips, G2	
11	10000039557	1	Assembly, mast junction box	

# MAST JUNCTION BOX ASSEMBLY - 296 WATT VERSION

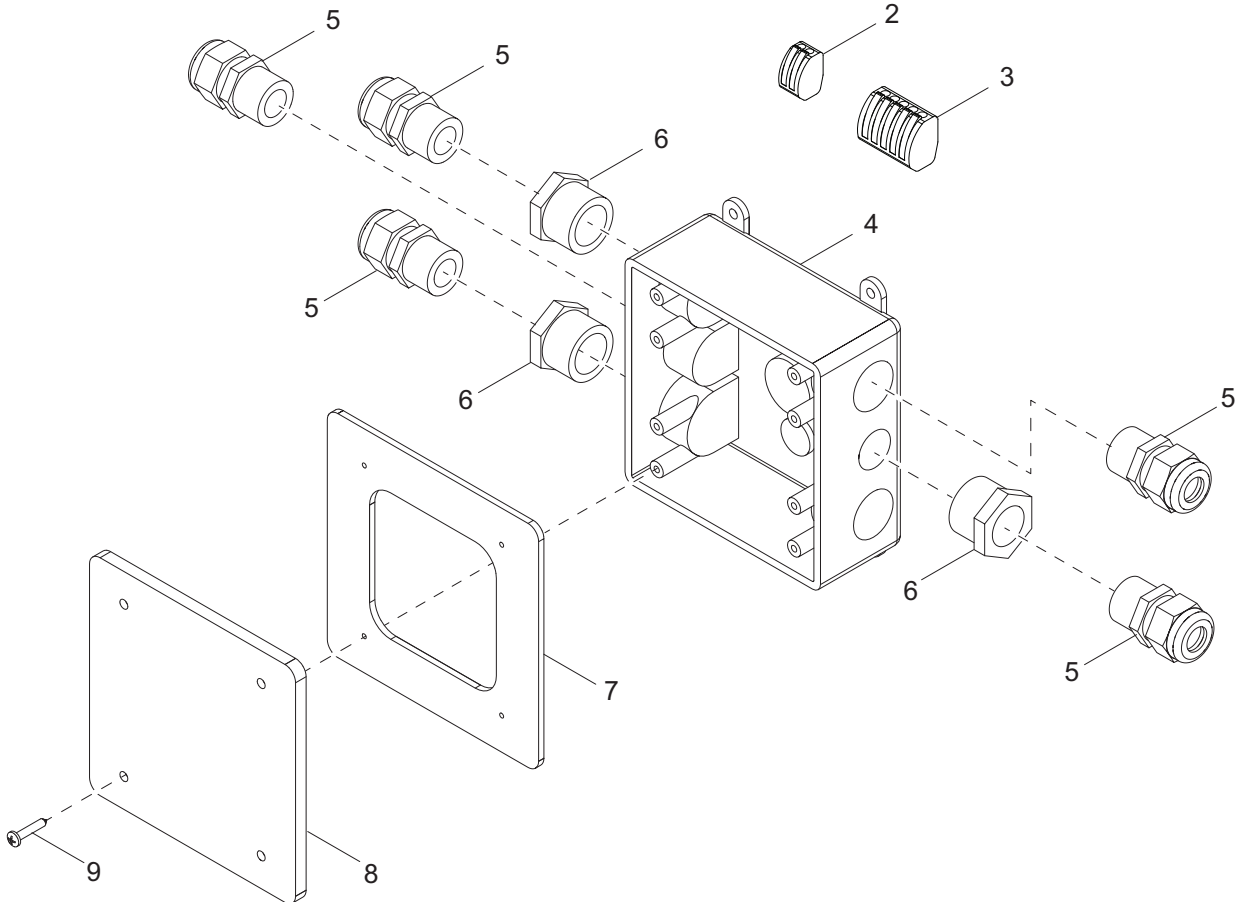
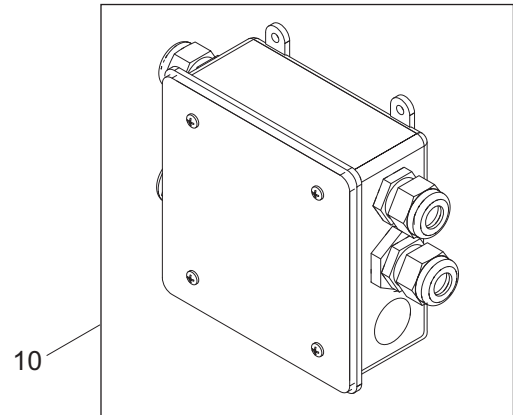
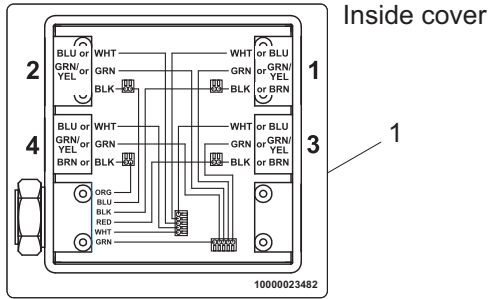

02607

## MAST JUNCTION BOX ASSEMBLY - 296 WATT VERSION

---

Item	Part No.	Qty	Description	Notes
1	10000023482	1	Decal, mast junction box	
2	66100	4	Connector, 2 position	
3	66102	2	Connector, 5 position	
4	12094	1	Box, junction	
5	60755	3	Fitting, straight .750MNPT x .500FNPT, nylon	
6	15864	5	Strain relief, .500NPT water tight	
7	13749SRV	1	Gasket, junction box - HFI 281000	
8	12109	1	Cover, box, 2-gang plastic	
9	60424	4	Screw, 6-32 x .750 pan Phillips, G2	
10	A0001500722	1	Assembly, mast junction box	

# DIFFUSED LIGHTING 296W (IF EQUIPPED)

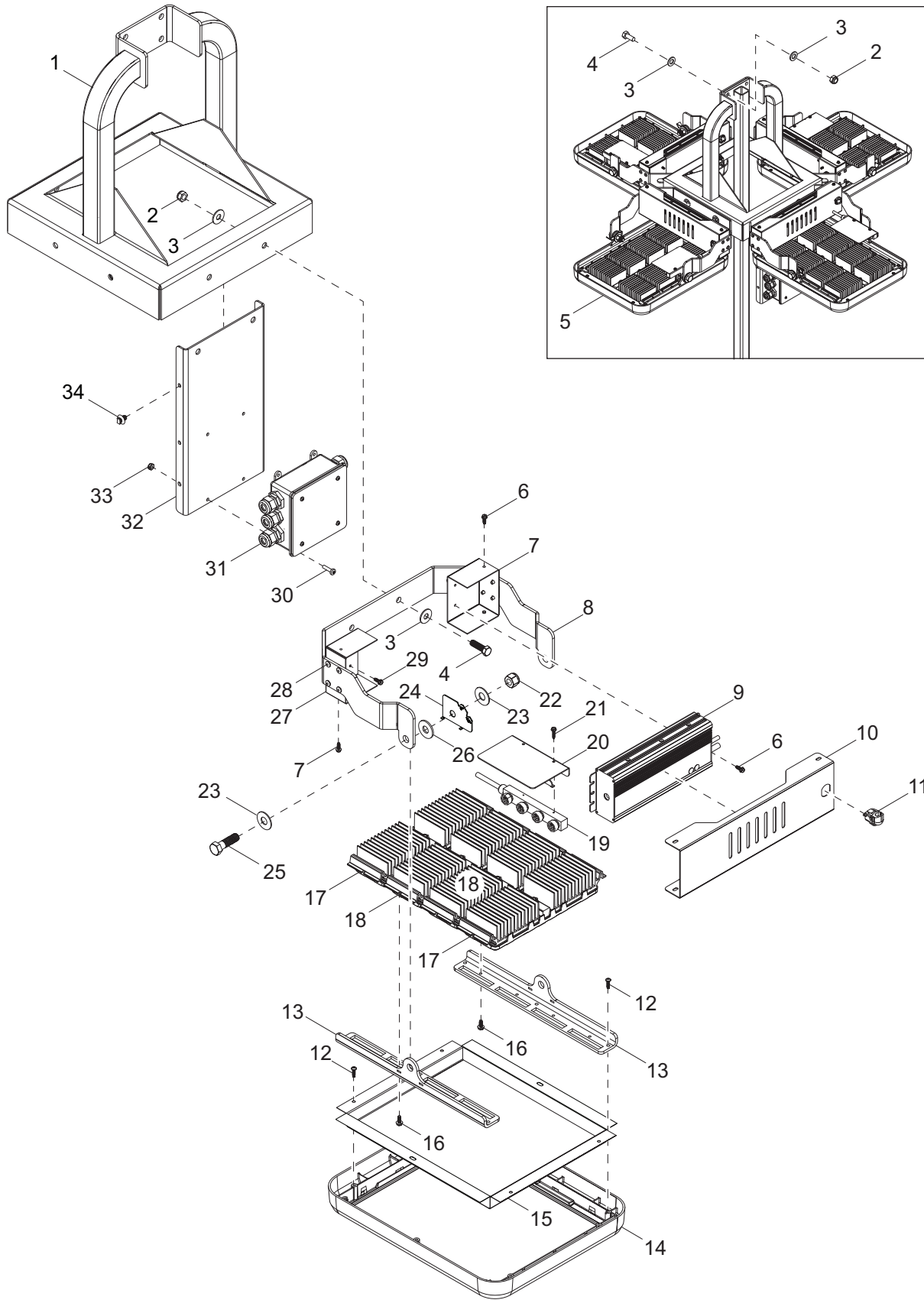

02703



## DIFFUSED LIGHTING 296W (IF EQUIPPED)

Item	Part No.	Qty	Description	Notes
1	10000035385	1	Weldment, mount 4 - diffused	
2	60358	12	Nut, .375-16 nylock, G5	
3	60386	24	Washer, .375 flat .993/-.64	
4	60352	12	Screw, .375-16 x 1.250 hex, G5	
5	10000035376	4	Assembly, 4 LED lights - diffused	
6	10000023706	8	Screw, 8-32 x .500 flanged hex	
7	10000023684	1	End cap 1, driver - LED	
8	10000035410	1	Bracket, trunnion - 4 mod diffused	
9	72178	1	Driver, LED 30V, 10.7A, 321W	
10	10000019153	1	Assembly, driver enclosure - LED	
11	10000019152	2	Bushing, strain relief - right angle	
12	10000019163	4	Screw, 8-16 x 8/8 pan Phillips - black	
13	10000046102	2	Support, horizontal frame, 4 module - LED	
14	10000019135	1	Assembly, end cap, horizontal - LED	
15	10000020598	1	Lens, diffuser 90°	
16	10000019182	8	Screw, 10-24 x .500 flanged hex - black	
17	10000019170	2	Module, 60° LED 24-27VDC 60W	
18	10000019160	2	Module, 40° 28 LED 24-27VDC	
19	72120	1	Connector block, 4 module - LED	
20	10000019164	1	Bracket, conn block	
21	73219	2	Screw, #6-20 x .750 sheet metal - SS	
22	62221	2	Nut, .500-13 nylock, G5	
23	60700	4	Washer, .500 flat 1.250/.060 - SS	
24	10000044708	1	Bracket, stop 45° - 4 mod diffused	
25	62249	2	Screw, .500-13 x 1.250 standard hex - SS	
26	72134	2	Washer, .500 nylon 1.25/.100	
27	10000023663	1	End cap 2, driver - LED	
28	60268	8	Rivet, .188 diameter x .126 t0 .250 grip - SS	
29	10000019172	1	Screw, 8-32 x 3/8 flanged hex - green	
30	60062	4	Screw, 10-32 x .750 pan Phillips, G2	
31	10000039557	1	Assembly, mast box - hard wire	
32	10000035367	1	Bracket, J box mount	
33	60061	4	Nut, 10-32 nylock	
34	66685	4	Mount, cable tie .25-.28 diameter, .031-.276 grip	
--	10000019079	4	Pigtail, 22-14GA, 3M, 314IDC	
--	10000023665	1	Cord, 18/3C, ST00W/SE00W 6.00 w/terminals	
--	34552	4	Clamp, tubing 1.00HD, .406 hole, .75WD	

# DIFFUSED LIGHTING 320W (IF EQUIPPED)

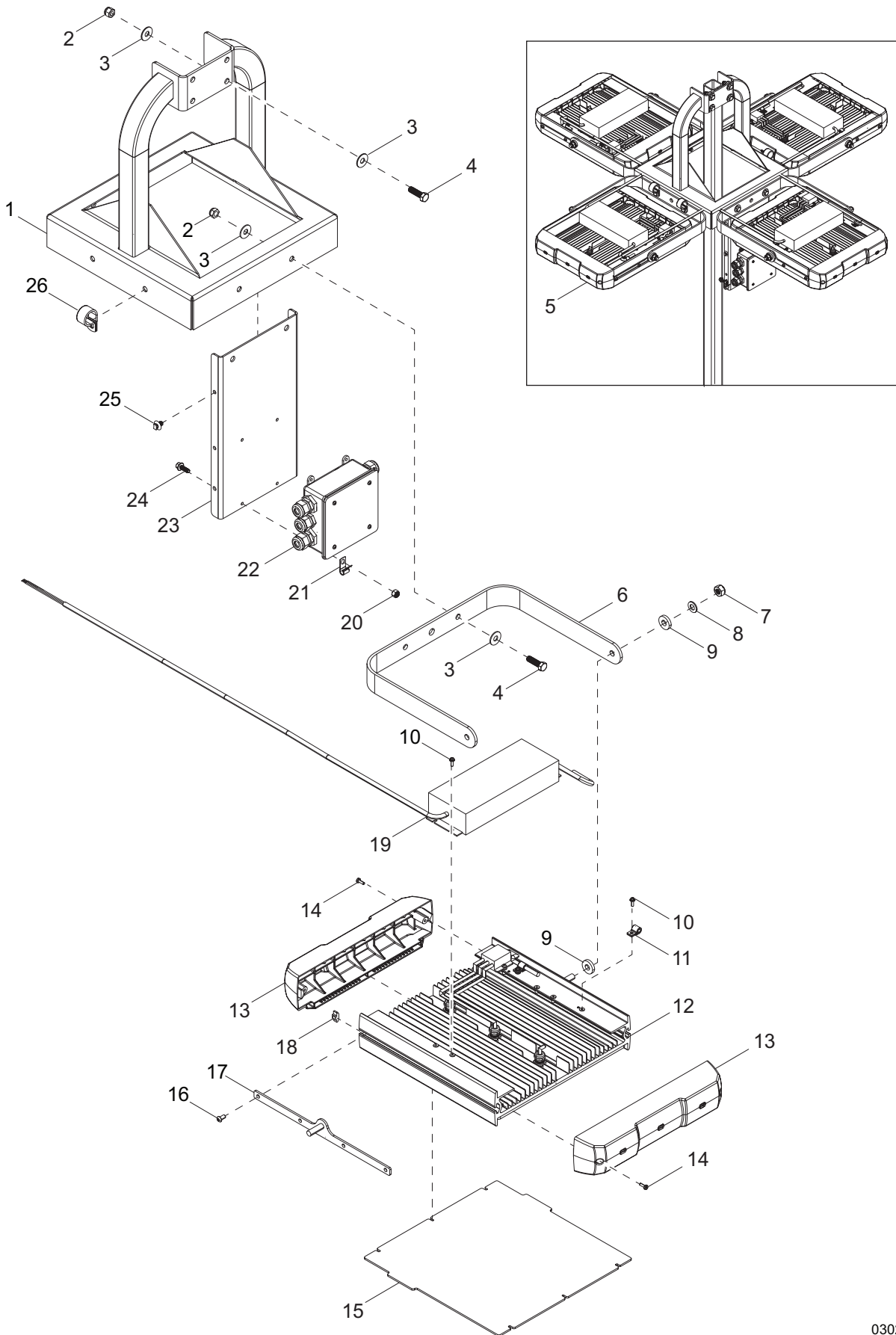

03023

## DIFFUSED LIGHTING 320W (IF EQUIPPED)

Item	Part No.	Qty	Description	Notes
1	10000035385	1	Weldment, mount 4 - diffused	
2	60358	12	Nut, .375-16 nylock, G5	
3	60386	24	Washer, .375 flat .993/-.64	
4	60352	12	Screw, .375-16 x 1.250 hex, G5	
5	A0001500725	1	Assembly, diffused lighting 320W	
6	A0000188712	1	Bracket, trunnion	
7	A0000009451	2	Nut, M10-1.50 nylock, G8.8	
8	60027	2	Washer, M10 flat	
9	A0000188752	4	Washer, M10 ID x 25MM OD x 5MM T	
10	0G7070	5	Screw, PPHM M4A0.7 x 14 SEMS	
11	G020151	2	Clamp, .312 x .203	
12	A0000188772	1	Assembly, 320W module - LED	
13	A0000092362	2	End cap, w/diffuser slot	
14	A0000188756	4	Screw, M4-0.7 x 12 - trilobular	
15	A0000095669	1	Lens, diffuser 320W - LED	
16	A0000214354	8	Screw, M6-1.0 x 12 button head hex - black	
17	A0000095202	2	Bracket, trunnion to frame	
18	A0000188739	8	Nut, M6-1.00 x 12 hammer	
19	A0000188779	1	Assembly, driver with connector	
20	60787	4	Nut, .250-20 nylock - SS	
21	60375	1	Clamp, tubing .312 - light duty	
22	A0000073922	1	Assembly, mast junction box	
23	10000035367	1	Bracket, J box mount	
24	60107	4	Screw, .250-20 x .750 serrated flange hex, G5	
25	66685	4	Mount, cable tie .25-28 diameter .031-.270 grip	
26	34552	4	Clamp, tubing 1.00HD, .406 hole, .75WD	
--	A0000098118	1	Assembly, coil cord	

# MAST ASSEMBLY

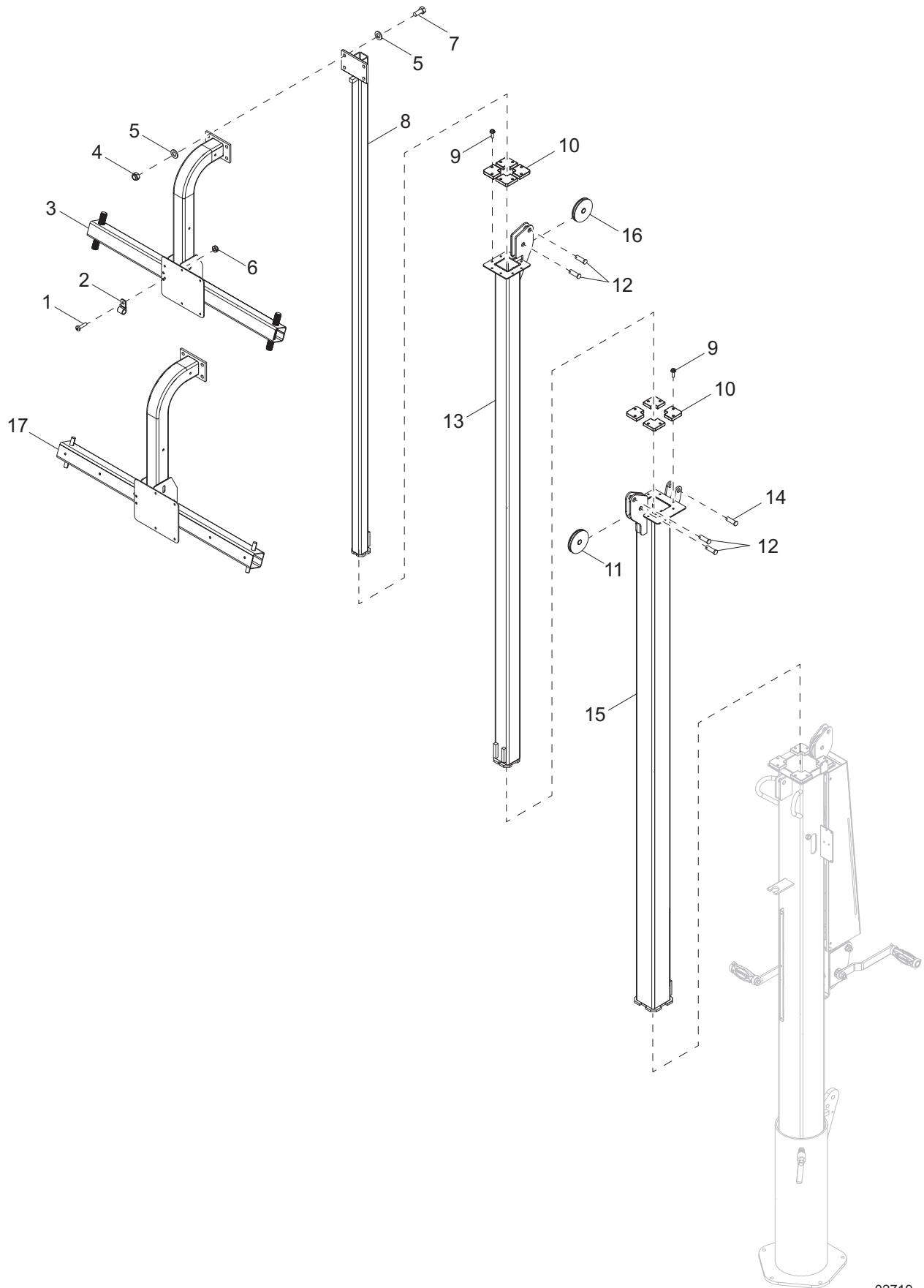

02719

## MAST ASSEMBLY

Item	Part No.	Qty	Description	Notes
1	60107	1	Screw, .250-20 x .750 serrated flange hex, G5	
2	60375	1	Clamp, tubing .312 - lt duty	
3	N/A	1	Weldment, mast, crossbar	call for more info
4	60358	4	Nut, .375-16 nylock, G5	
5	60386	8	Washer, .375 flat .993/.064	
6	60787	1	Nut, .250-20 nylock - SS	
7	60352	4	Screw, .375-16 x 1.250 hex, G5	
8	31264B	1	Weldment, mast - 1.50	
9	63358	16	Screw, .250-20 x .625 hex wash hd	
10	31225	8	Guide	
11	33736	1	Assembly, pulley - vertical mast	
12	63325	4	Pin, clevis .500 diameter x 1.063 UL	
13	31261B	1	Weldment, mast - 2.25	
14	35655	1	Pin, clevis .500 diameter x 1.750 ZP	
15	37465B	1	Weldment, mast - 3.0	
16	14262	1	Sheave, 3.00	
17	A0000199129	1	Weldment, mast, crossbar	320W version
--	31247	1	Cable, .188 x 144 w/ball swedge	winch cable
--	31248	2	Cable, .188 x 79.750 w/ball swedge	middle cable
--	31277	1	Cable, .188 x 78.0 w/ball swedge	top cable

# MAST ASSEMBLY - BOTTOM POST - MANUAL WINCH

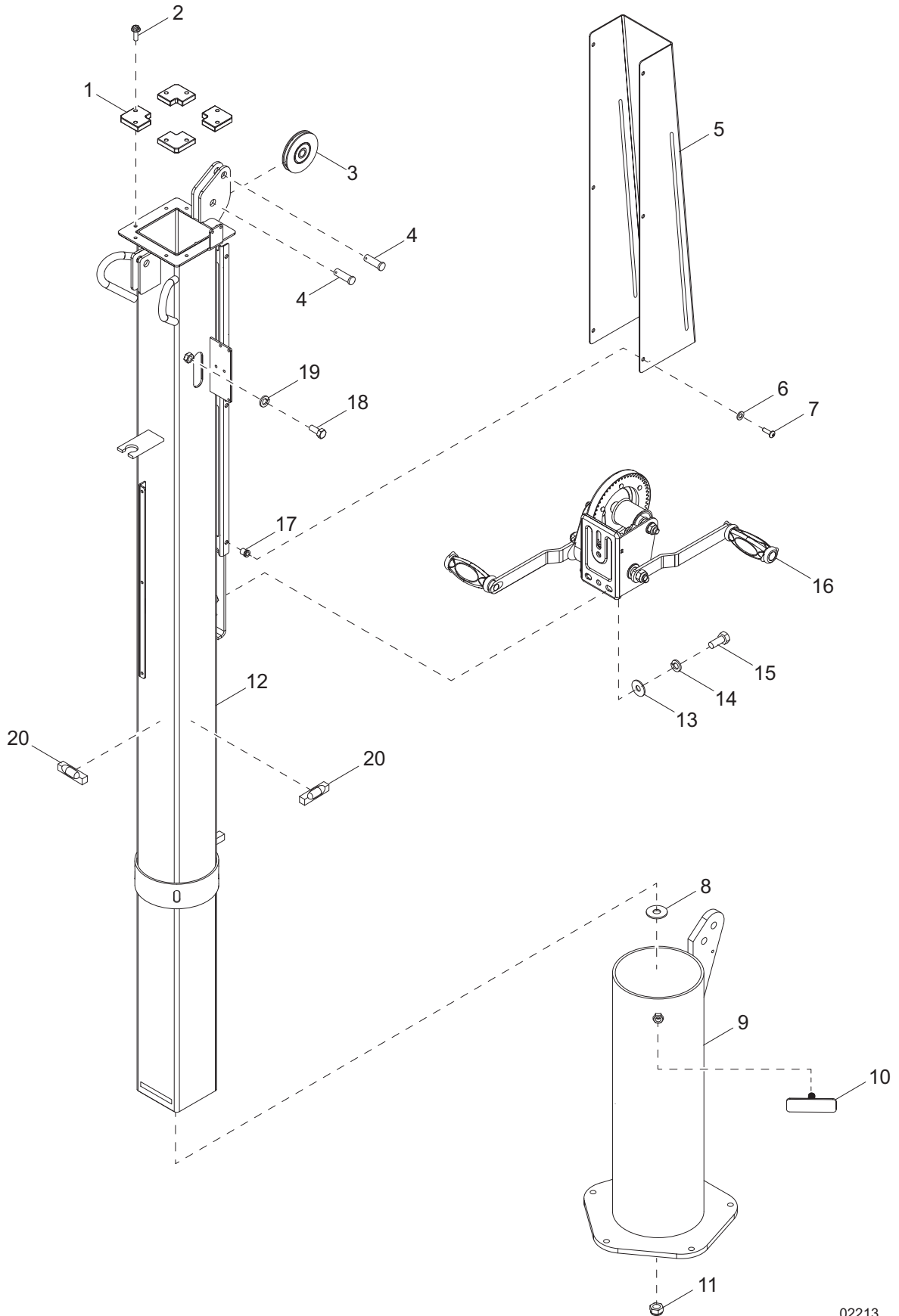

## MAST ASSEMBLY - BOTTOM POST - MANUAL WINCH

Item	Part No.	Qty	Description	Notes
1	31225	4	Guide	
2	63358	8	Screw, .250-20 x .625 hex washer head	
3	33736	1	Assembly, pulley vertical mast	
4	63325	2	Pin, clevis .500 diameter x 1.063 UL	
5	72116B	1	Guard, cable	
6	60067	6	Washer, #10 flat .435/.060 - SS	
7	60398	6	Screw, 10-32 x .500 pan Phillips - SS	
8	60247	1	Washer, .750 flat 2.020/.130	
9	31218B	1	Weldment, mast rotation tube	
10	10000018317	1	Weldment, T-handle	
11	60584	1	Nut, .750-10 nylock, G5	
12	73158B	1	Weldment, mast 4.0 in	
13	60386	3	Washer, .375 flat .993/.064	
14	60206	3	Washer, .375 split lock - hardened	
15	60205	3	Screw, .375-16 x 1.0 hex, G5	
16	72127	1	Winch, manual - 1500 lb, dual handle	
17	32922	6	Insert, threaded 10-32 splined, .020-.130 grip	
18	62269	2	Screw, .375-16 x .75 hex, SS - red	
19	60703	2	Washer, .375 split lock, SS	

# MAST ASSEMBLY - BOTTOM POST - ELECTRIC WINCH

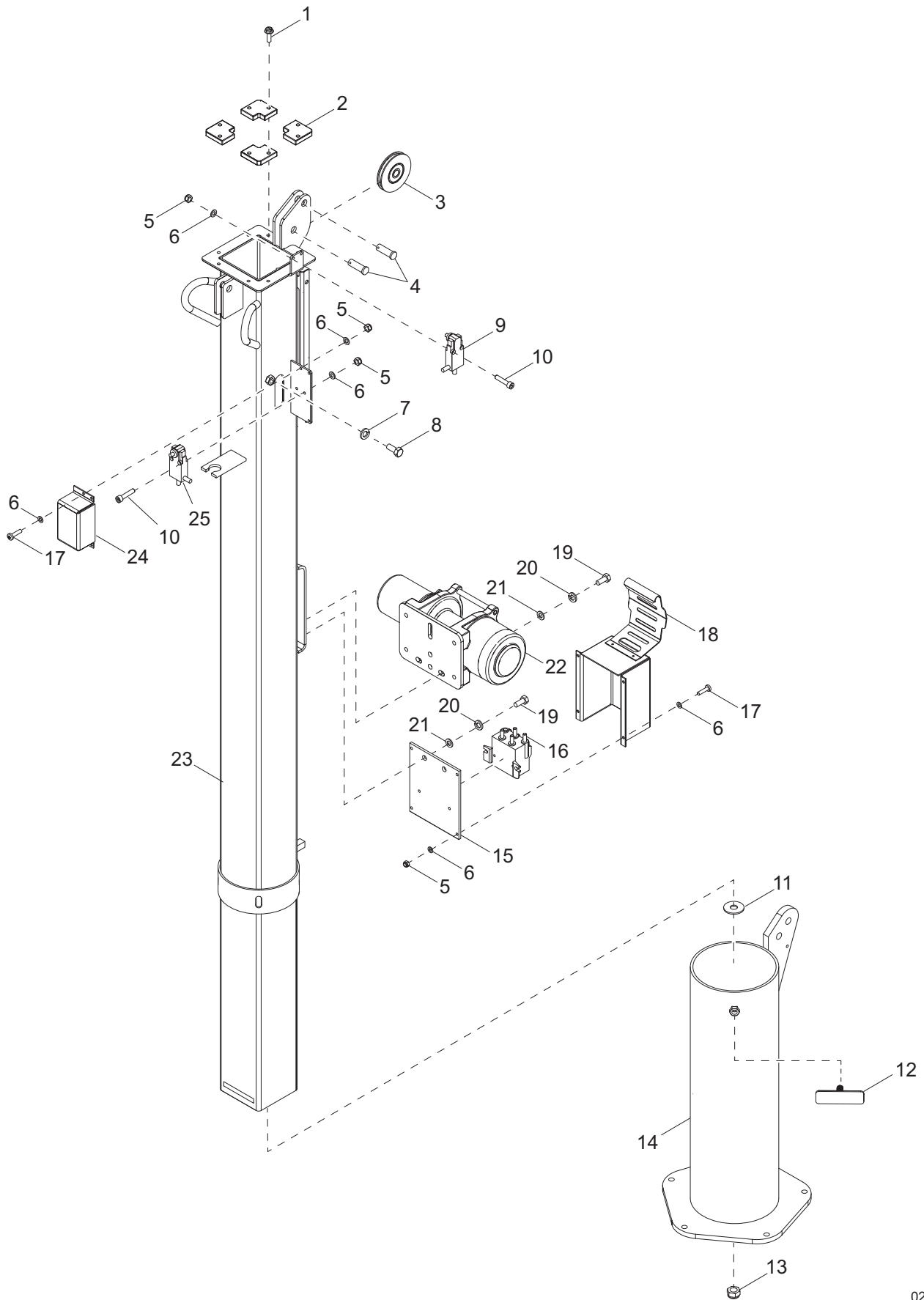

02580



## MAST ASSEMBLY - BOTTOM POST - ELECTRIC WINCH

Item	Part No.	Qty	Description	Notes
1	63358	8	Screw, .250-20 x .625 hex washer head	
2	31225	4	Guide	
3	33736	1	Assembly, pulley vertical mast	
4	63325	2	Pin, clevis .500 diameter x 1.063 UL	
5	60270	11	Nut, 8-32 nylock, G6	
6	60269	18	Washer, #8 flat .433/.036	
7	60703	2	Washer, .375 split lock, SS	
8	62269	2	Screw, .375-16 x .75 hex, SS - red	
9	31740	1	Assembly, down switch	
10	67190	4	Screw, 8-32 x 1.125 socket head, SS	
11	60247	1	Washer, .750 flat 2.020/.130	
12	10000018317	1	Weldment, T-handle	
13	60584	1	Nut, .750-10 nylock, G5	
14	31218B	1	Weldment, mast rotation tube	
15	37207B	1	Plate, contactor	
16	11293	1	Contactor	hardware included
17	60244	7	Screw, 8-32 x .750 pan Phillips, G2	
18	37468B	1	Weldment, winch cover	
19	60205	5	Screw, .375-16 x 1.0 standard hex, G5	
20	60206	5	Washer, .375 split lock	
21	60386	5	Washer, .375 flat .993/.064	
22	12874	1	Winch, electric - 770 lb hoist	
23	73158B	1	Weldment, mast 4.0 in	
24	37205B	1	Cover, up limit switch	
25	31739	1	Assembly, up stop switch	
--	12922	2	Boot, battery cable - red	
--	31742	1	Wire group, electric winch box	
--	31743	1	Harness, winch power cables	

# ENCLOSURE ASSEMBLY (1 OF 2)

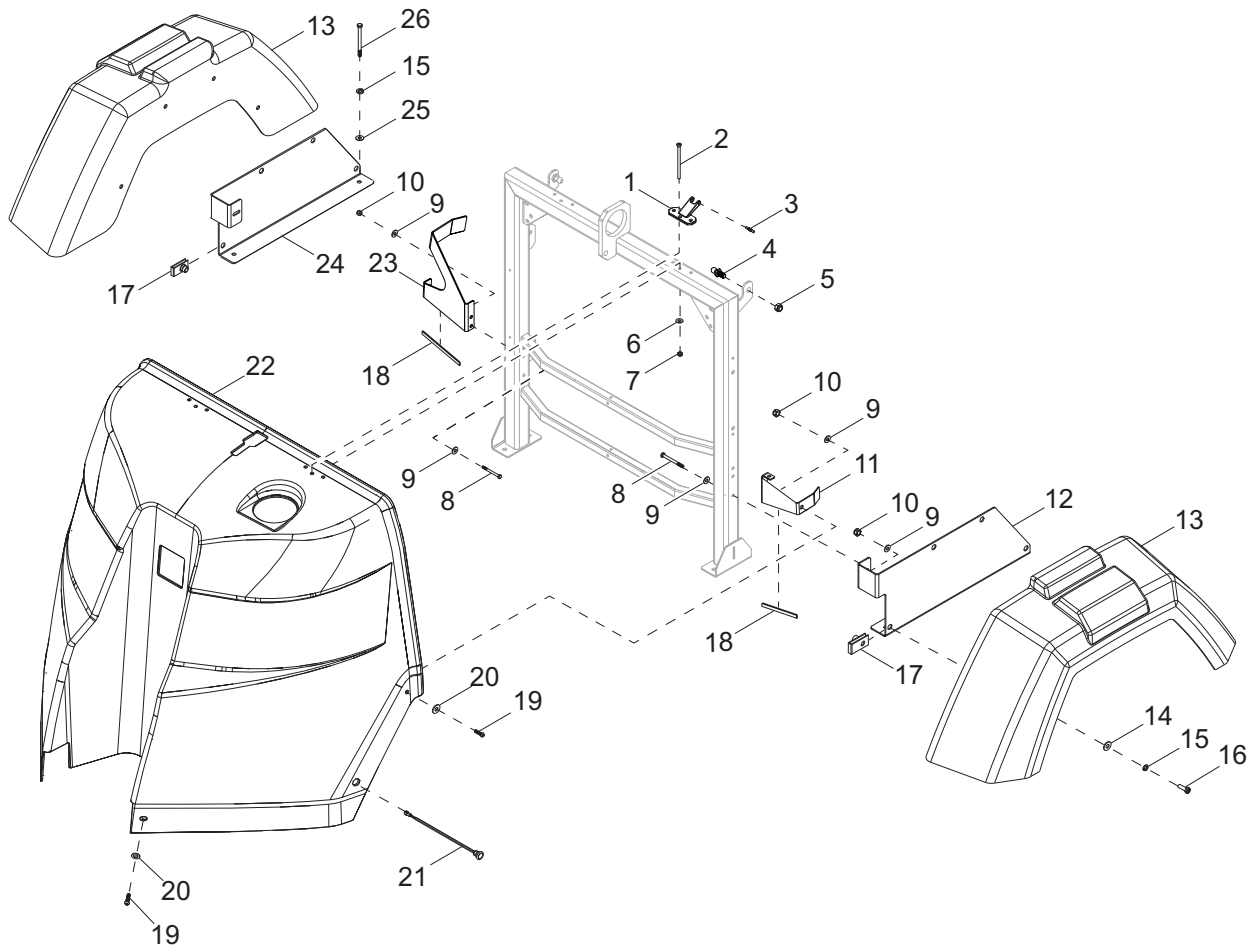

02435

**ENCLOSURE ASSEMBLY (1 OF 2)**

<b>Item</b>	<b>Part No.</b>	<b>Qty</b>	<b>Description</b>	<b>Notes</b>
1	10000022542	2	Hinge, offset housing leaf - front	
2	35282	6	Screw, 10-24 x 3.0 flat head Phillips, SS	
3	10000022543	2	Pin, offset housing hinge - knurled	
4	35293	2	Ball stud, 10mm, .313-18	
5	60303	2	Nut, .312-18 nylock, G2	
6	60237	12	Washer, #10 flat .495/.036	
7	60457	12	Nut, 10-24 nylock, G2	
8	61234	6	Screw, .250-20 x 2.750 standard hex, G5	
9	60243	12	Washer, .250 flat .735/.060	
10	60144	8	Nut, .250-20 nylock, G5	
11	10000017357	1	Guide bracket, enclosure meeting -LH	
12	35141B	1	Bracket, mounting fender - left	
13	10000017287	2	Fender, plastic, 13 in. wheel - textured black	
14	60386	8	Washer, .375 flat .993/.064	
15	60271	8	Washer, .312 split lock	
16	60028	8	Screw, .312-18 x 1.0 standard hex, G5	
17	62086	8	Nut, .312-18 U-clip - short type	
18	68070	4	Screw, .250-20 x 1.00 button hex, SS	
19	60696	6	Washer, .250 flat .625/.050, SS	
20	36961	2	Assembly, amber side marker light	
21	10000012597	1	Enclosure, front cover	
22	10000017378	1	Guide bracket, enclosure meeting -RH	
23	35216B	2	Bracket, mounting fender - right	
24	60119	6	Washer, .312 flat .875/.070	
25	60404	4	Screw, .312-18 x 1.250 standard hex, G5	

# ENCLOSURE ASSEMBLY (2 OF 2)

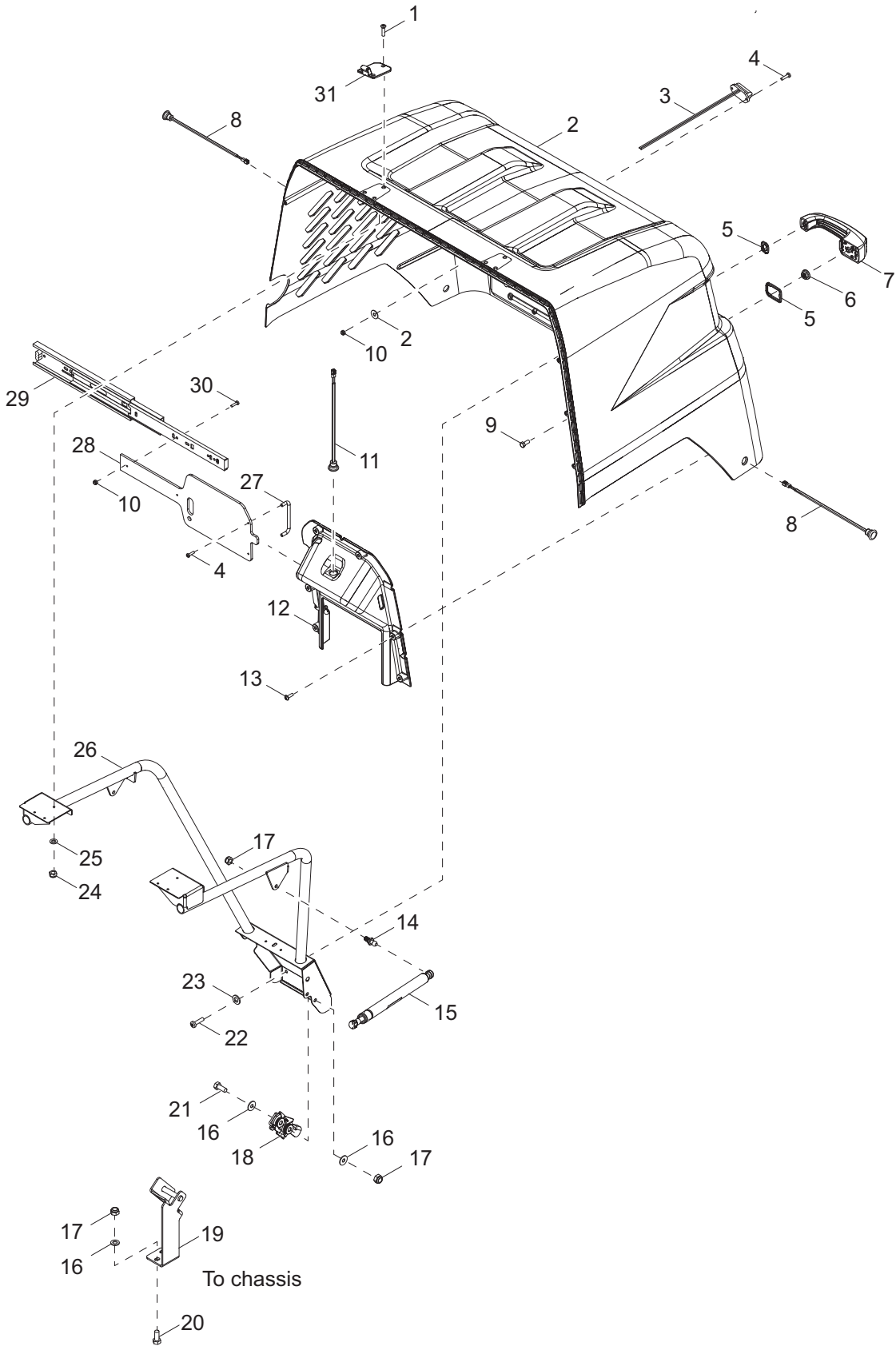

02436

## ENCLOSURE ASSEMBLY (2 OF 2)

Item	Part No.	Qty	Description	Notes
1	35290	6	Screw, 10-24 x 1.00 flat Phillips, SS	
2	10000012638	1	Housing, rear textured - orange	
3	36963	1	Assembly, license plate light	
4	60694	4	Screw, 8-32 x .750 pan Phillips, SS	
5	70216	1	Gasket, kit handle, push button	
6	60036	1	Nut, M6-1.00 serrated flange, G8.8	
7	35138	1	Handle, push-button padlock	
8	36962	2	Assembly, red side marker	
9	60335	1	Screw, M6-1.00 x 25 standard hex, SS	
10	60270	4	Nut, 8-32 nylock, class 6	
11	36964	1	Assembly, controls light	
12	10000012596	1	Bezel, control panel textured - black	
13	10000017348	6	Screw, D60-2.14 x 20TRWH	
14	35293	2	Ball stud, 10mm, .313-18	
15	35137	2	Gas shock, 120 lb	
16	60119	6	Washer, .312 flat .875/.070	
17	60303	6	Nut, .312-18 nylock, G2	
18	35139	1	Latch, rotary	
19	37178B	1	Mount, door latch striker	
20	61066	2	Screw, .312-18 x 1.00 carriage square - SS	
21	62001	2	Screw, .312-18 x 1.250 standard hex, G5	
22	60146	3	Screw,	
23	60243	3	Washer, .250 flat .735/.060	
24	60457	6	Nut, 10-24 nylock, G2 ZC	
25	60237	2	Washer, #10 flat .495/.036 ZC	
26	37012B	1	Weldment, enclosure structure	
27	37123	1	Handle, control box cover	
28	10000017623	1	Cover, sliding control panel	
29	36914	1	Slide, control box cover	
30	62054	2	Screw, 8-32 x .500 pan Phillips - SS	
31	10000022523	2	Hinge, leaf offset housing - rear	
--	10000028590	1	Assembly, rear enclosure	Items 1-31
--	60335	1	Screw, M6-1.00 x 25 standard hex, SS	
--	60375	1	Clamp, tubing - .312 lt duty	

# CONTROL BOX ASSEMBLY

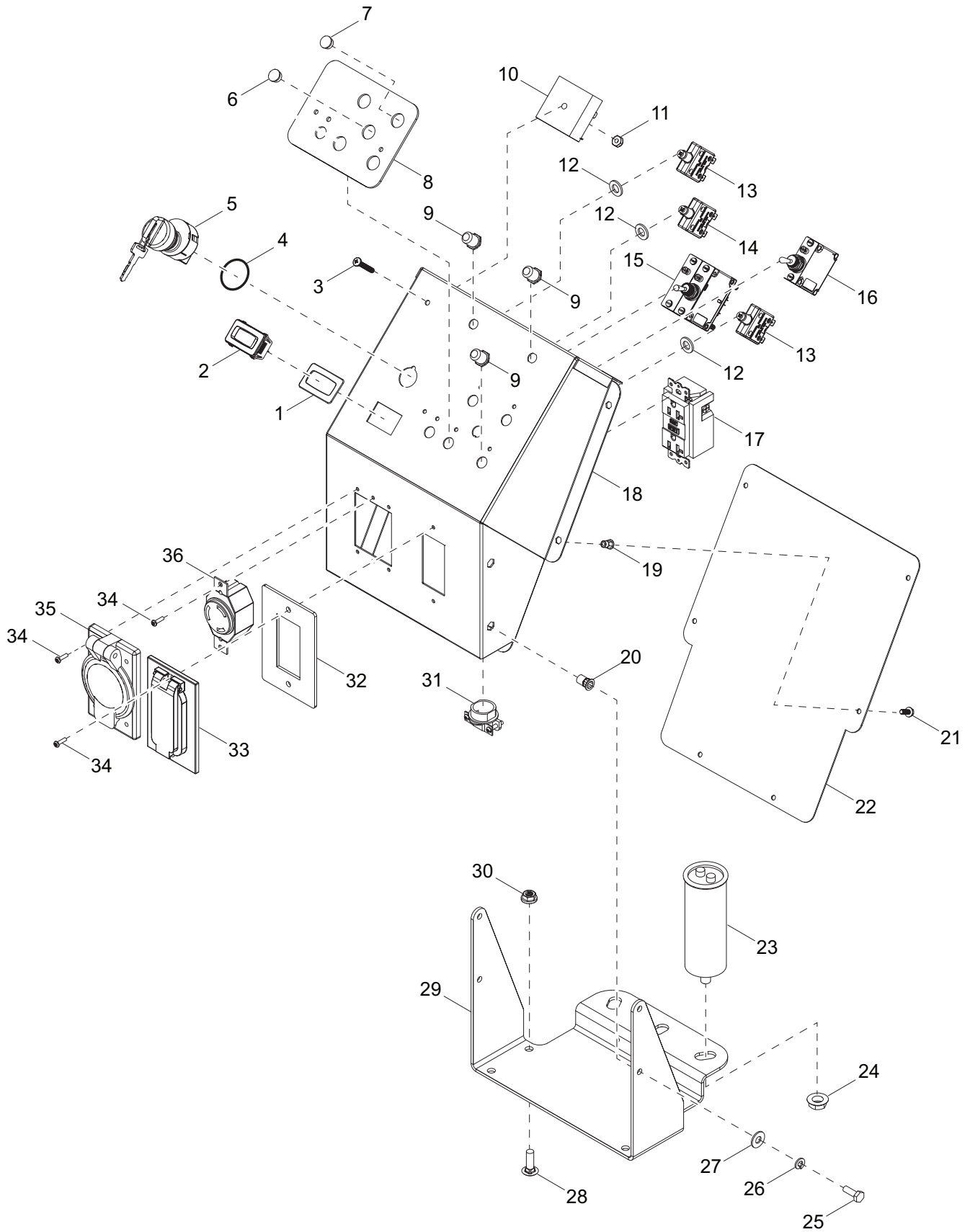

02680

## CONTROL BOX ASSEMBLY

Item	Part No.	Qty	Description	Notes
1	36944	1	Gasket, hour meter	
2	36886	1	Meter, hour	
3	63308	1	Screw, 10-32 x 1.250 pan Phillips, SS	
4	37042	1	O-ring, .75IDx15-16 in. x 3/32 in	
5	36882	1	Switch, sealed key, 4-position	
6	65798	1	Plug, hole .468 x .06	Manual mast only
7	65479	2	Plug, hole .500 x .125 - plastic	
8	10000034973	1	Decal, control panel	
9	36938	3	Boot, push button breaker	
10	14201	1	Relay, 10A SPDT, time delay - 15 sec fixed	
11	60061	1	Nut, 10-32 nylock	
12	60386	3	Washer, .375 flat .993/.064	
13	36937	2	Breaker, 10A DC	
14	36935	1	Breaker, 15A, 1 pole, 250V	
15	36975	1	Breaker, 30A main	
16	10000035999	1	Switch, 10 amp	
17	14130	1	Receptacle, 120V/20A GFI	
18	36884B	1	Control box	
19	62234	6	Insert, threaded #10-32 hex .020-.130 grip	
20	63231	4	Insert, threaded .250-20 hex .027-.165 grip	
21	62254	6	Screw, 10-32 x .500 serrated flange, SS	
22	36885B	1	Cover, control panel box	
23	36980	1	Capacitor, 25 $\mu$ F, 5% 440VAC, sealed stud mount	
24	60148	1	Nut, M12-1.75 serrated flange, G8.8	
25	60281	4	Screw, .250-20 x .750 standard hex, G5	
26	60286	4	Washer, .250 split lock	
27	60243	4	Washer, .250 flat .735/.060	
28	61066	4	Screw, .312-18 x 1.0 carriage, SS	
29	38409B	1	Bracket, control box mounting	
30	60095	4	Nut, .312-18 serrated flange	
31	14219	1	Strain relief - .75 Romex w/nut	
32	A0001500724	1	Gasket, receptacle cover	
33	36939	1	Cover, receptacle - weather proof 20/30A twist-lock	
34	62210	6	Screw, 6-32 x .50 pan Phillips, SS	
35	37017	1	Cover receptacle - weather proof, 20A GFCI single	
36	14137	1	Receptacle, 240V/30A twist	
--	60728	6	Nut, 6-32 nylock, G5	use with 62210
--	65707	1	Switch, toggle - SPDT spring	Electric mast only
--	68282	1	Wire group, control box - electric mast	
--	68283	1	Harness, generator to control box	
--	68284	1	Harness, control box to electric mast	

# CONTROL BOX ASSEMBLY - POWER ZONE OPTION (1 OF 2)

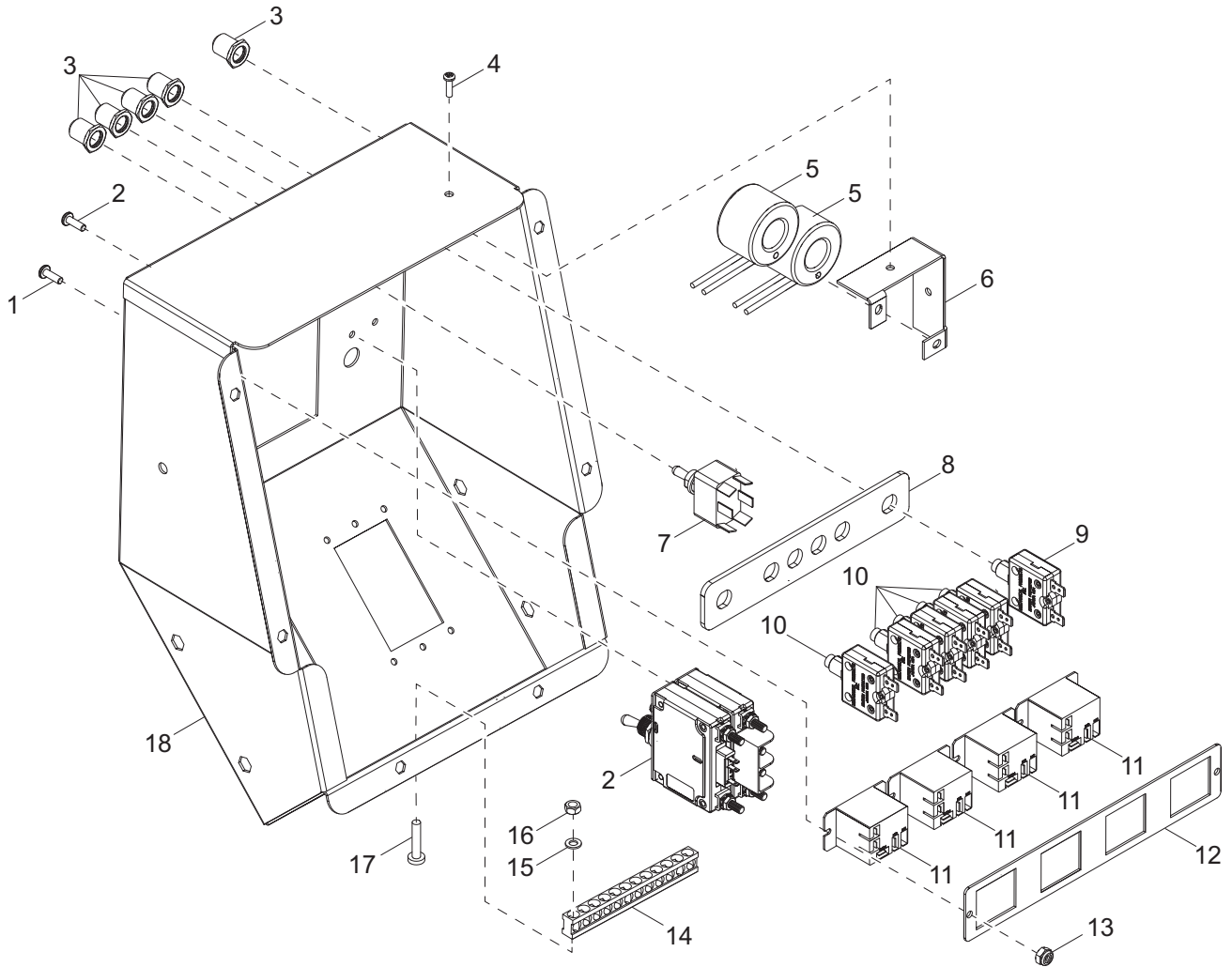

02345



## CONTROL BOX ASSEMBLY - POWER ZONE OPTION (1 OF 2)

Item	Part No.	Qty	Description	Notes
1	62054	3	Screw, 8-32 x .500 pan Phillips,- SS	
2	36975	2	Breaker, 30A main	with hardware
3	36938	6	Boot, push button breaker	
4	62210	6	Screw, 6-32 x .50 pan Phillips - SS	
5	66255	2	Transformer, current	
6	38449B	1	Bracket, CT mount	
7	10000031493	1	Switch, toggle - SPST 20A sealed	
8	38448B	1	Spacer, breaker control box	
9	36937	1	Breaker, 10A DC	
10	36935	5	Breaker, 15A, 250V, 1 pole	
11	29759	4	Relay, 12V coil 120-240 VAC rated	
12	38447B	1	Bracket, relay	
13	60270	3	Nut, 8-32 nylock, G6	
14	14204	1	Kit, ground bar	
15	60252	6	Washer, #10 split lock	
16	60318	2	Nut, 8-32 Hex, G5	
17	60406	2	Screw, 8-32 x 1.00 pan Phillips, G2	
18	37823B	1	Box, control - PZ	

# CONTROL BOX ASSEMBLY - POWER ZONE OPTION (2 OF 2)

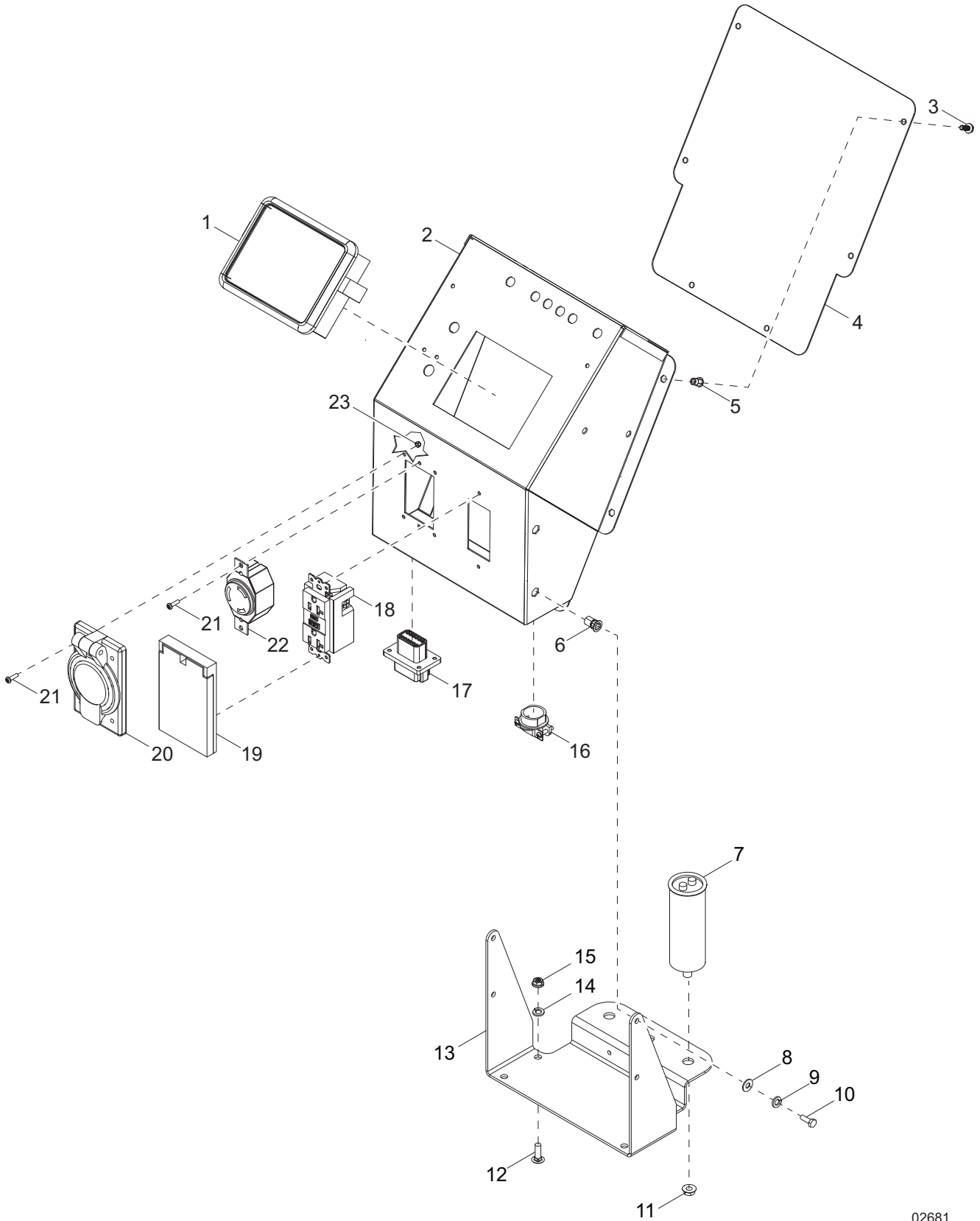

02681

## CONTROL BOX ASSEMBLY - POWER ZONE OPTION (2 OF 2)

Item	Part No.	Qty	Description	Notes
1	CALL	1	Controller, Deep Sea - programmed	
2	37823B	1	Box, PZ control panel	
3	60277	6	Screw, 10-32 x .500 pan Phillips, G2	
4	38413B	1	Cover, control panel box	
5	62234	6	Insert, 10-32 hex, .020-.130 grip, threaded	
6	63231	4	Insert, .250-20 hex, .027-.165 grip, threaded	
7	36980	1	Capacitor, 25 $\mu$ F 5% 440VAC, sealed stud mount	
8	60243	4	Washer, .250 flat .735/.060	
9	60286	4	Washer, .250 split lock	
10	60647	4	Screw, .250-20 x .500 hex, G5	
11	60148	3	Nut, M12-1.75 serrated flange, G8.8	
12	61066	4	Screw, .312-18 x 1.0 carriage - SS	
13	38409B	1	Bracket, control box mounting	
14	60119	4	Washer, .312 flat .875/.070	
15	60095	4	Nut, .312-18 serrated flange - case hardened	
16	14219	2	Strain relief, .75 Romex w/nut	
17	66695	1	Connector, Duetsch 12 position - flange DT	
18	14130	1	Receptacle, 120V/20A GFI	
19	37017	1	Cover, receptacle 20A GFCI single - weatherproof	
20	36939	1	Cover, receptacle 20/30A - weatherproof	
21	62210	6	Screw, 8-32 x .500 pan Phillips - SS	
22	14137	1	Receptacle, 250V/ 30A twist	
23	60728	6	Nut, 6-32 nylock, G5	
--	68534	1	Harness, control box PZ	replaces p/n 68284
--	68535	1	Harness, gen to control box PZ	replaces p/n 68283
--	36928	1	Harness, engine PZ	

# COOLING SYSTEM ASSEMBLY

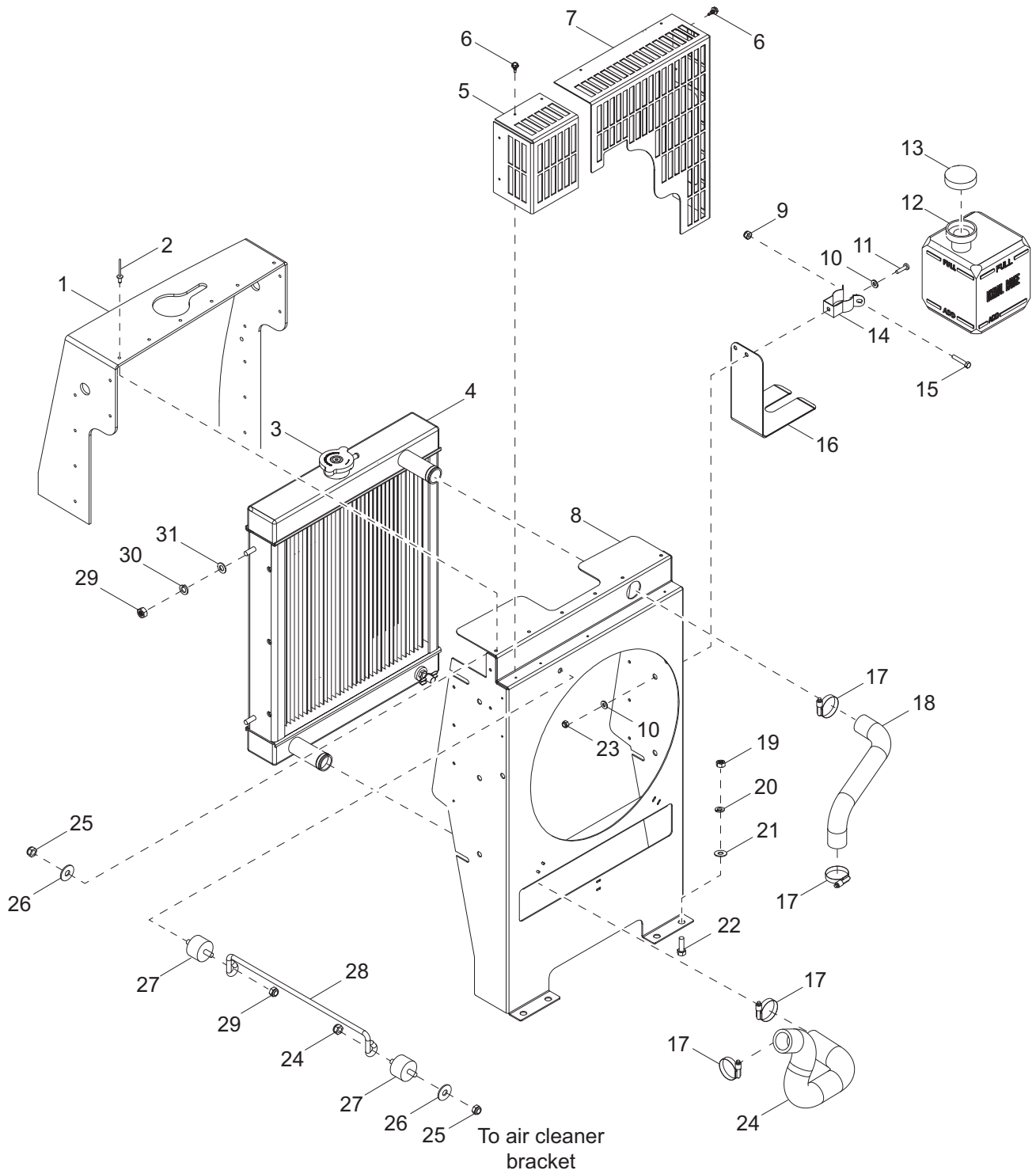

02682

## COOLING SYSTEM ASSEMBLY

Item	Part No.	Qty	Description	Notes
1	36979	1	Seal, rubber, cooling	
2	60195	18	Rivet, .188 dia. x .375 to .500 grip, large flange	
3	19219	1	Cap, radiator pressure small - 14.7 psi	
4	A0000335661	1	Radiator	
5	36227B	1	Guard, fan, left	
6	60364	9	Screw, 10-16x5.0 std hex, G2	
7	36232B	1	Guard, fan, right	
8	36233B	1	Fan shroud	
9	60144	1	Nut, .250-20 nylock, G5	
10	60067	4	Washer, #10 flat .435/.060, SS	
11	61180	2	Screw, 10-32 x .750 pan Phillips, SS	
12	20287	1	Jug, overflow 2 qt. (.5 gal)	
13	19714	1	Cap, overflow jug	
14	19726	1	Clamp, overflow bottle	
15	60414	1	Screw, .250-20 x 1.50 standard hex, G5	
16	22419B	1	Bracket, support overflow jug .5 gallon	
17	15422	4	Clamp, hose - SAE 020 (.75-1.75)	
18	36977	1	Hose, radiator - upper	
19	60285	14	Nut .312-18 hex, G2	
20	60271	21	Washer, .312 split lock	
21	60119	24	Washer .312 flat .875/.070	
22	61066	4	Screw, .312-18 x 1.00 carriage square 18-8 SS	
23	60061	1	Nut, 10-32 nylock	
24	12350	1	Hose, radiator - lower	
25	62079	4	Nut, .312-18 nylock jam	
26	60119	2	Washer, .312 flat .875/.070	
27	34052	2	Isolator, rubber 1.50 x 1.0, 5/16-18 studs	
28	36989	1	Rod, radiator stay	
29	60032	4	Nut, M8-1.25 hex, G8.8	
30	60029	2	Washer, M8 split lock	
31	60166	2	Washer, M8 flat	

# ENGINE ASSEMBLY (1 OF 2)

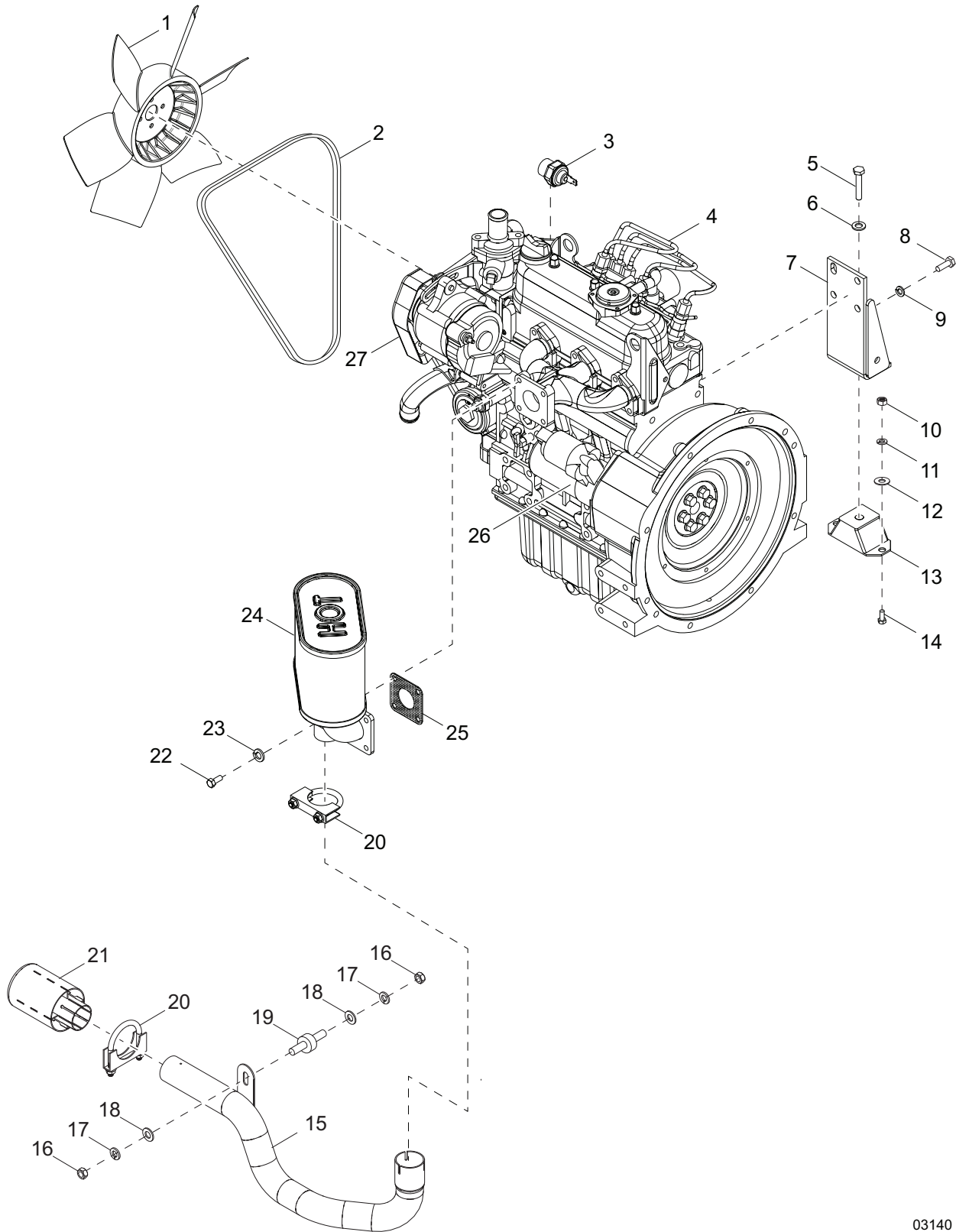

03140

## ENGINE ASSEMBLY (1 OF 2)

Item	Part No.	Qty	Description	Notes
1	15495	1	Fan, pusher	
2	11628	1	V-belt	
3	14099	1	Switch, coolant temperature	
4	13310	1	Engine, Kubota D1005-E3BG1-MGM-1	
5	60275	4	Screw, .500-13 x 1.00 standard hex, G5	
6	60702	4	Washer, .500 split lock, SS	
7	12338B	2	Weldment, engine mount	
8	60422	8	Screw, M10-1.25 x 25 standard hex, G8.8	
9	60026	8	Washer, M10 split lock	
10	60285	4	Nut, .312-18 hex, G2	
11	60271	4	Washer, .312 split lock	
12	60119	4	Washer, .312 flat .875/.070	
13	15241	2	Isolator, rubber 80-200 lbs., 2" wide	
14	61066	4	Screw, .312-18 x 1.00 carriage, SS	
15	10000033352	1	Tube, exhaust	
16	60285	2	Nut, .312-18 hex, G2	
17	60271	2	Washer, .312 split lock	
18	60119	2	Washer, .312 flat .875/.070	
19	34052	1	Isolator, 1.50 x 1.00 - .312-18 studs	
20	68082	2	Clamp, muffler 1.63	
21	10000021954		Tip, exhaust	
22	63168	4	Screw, M8-1.25 x 30 standard hex, 10.9	
23	60029	4	Washer, M8 split lock	
24	17949	1	Muffler	
25	11042SRV	1	Gasket, muffler	
26	30582	1	Starter, D1005	
27	12486	1	Alternator	

**Note:** Engine and generator parts used in all Generac Mobile Products, LLC equipment carry the Original Equipment Manufacturer (OEM) warranty unless otherwise stated. OEM warranty parts must be purchased through an OEM dealer. Please contact Generac Mobile Products, LLC with questions.

# ENGINE ASSEMBLY (2 OF 2)

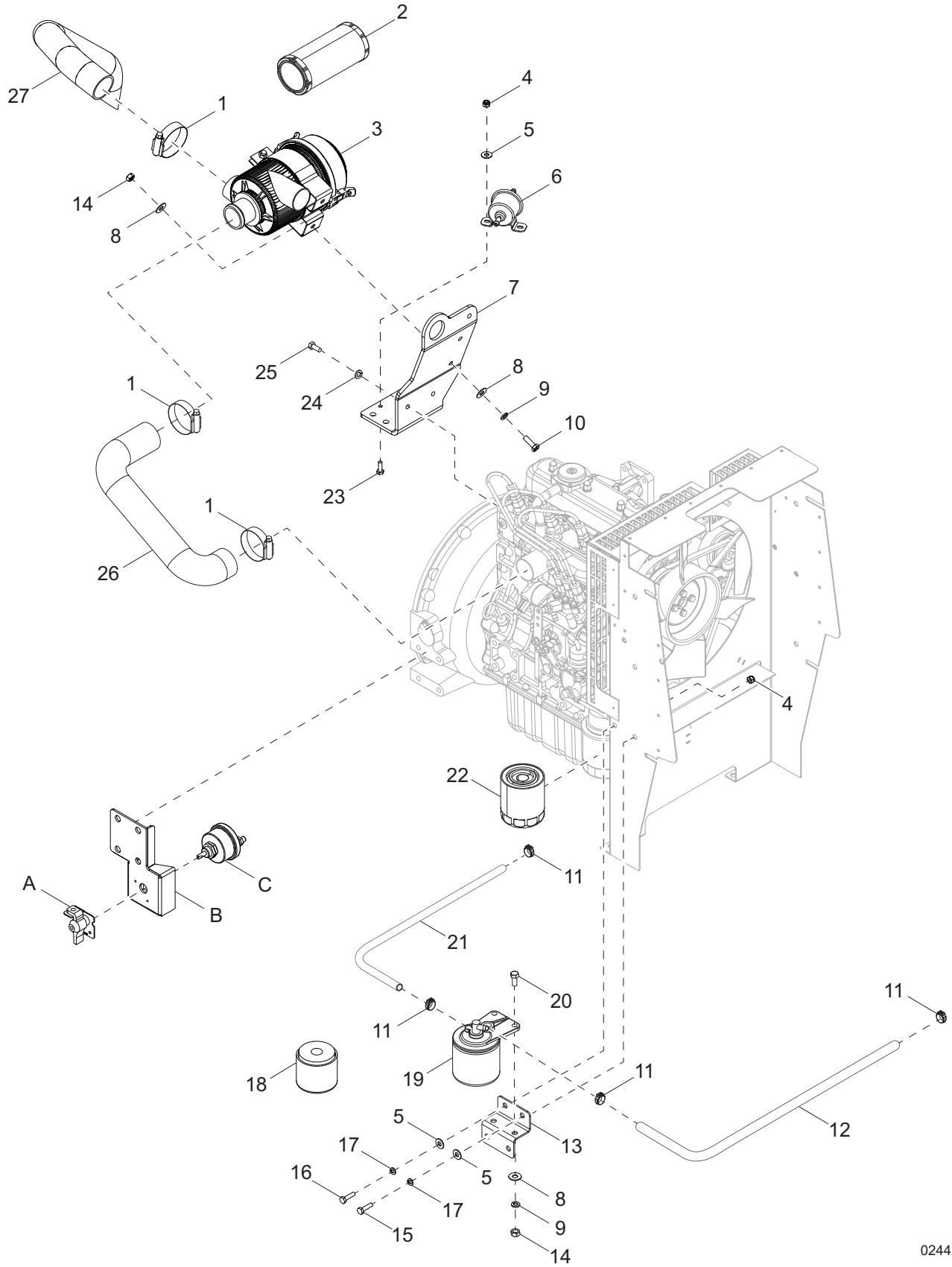

02441



## ENGINE ASSEMBLY (2 OF 2)

Item	Part No.	Qty	Description	Notes
1	60316	3	Clamp, hose - SAE 032 (1.56-2.50)	
2	16444	1	Element, air filter	
3	10000021718	1	Filter, air, w bracket	incl. 16444
4	60144	3	Nut, .250-20 nylock, G5	
5	60243	6	Washer, .250 flat .735/.060	
6	13278SRV	1	Fuel pump, electric	
7	17977B	1	Bracket, air cleaner	
8	60119	6	Washer, .312 flat .875/.070	
9	60271	4	Washer, .312 split lock	
10	60028	2	Screw, .312-18 x 1.00 standard hex, G5	
11	60777	4	Clamp, hose - .312 fuel hose crimp style	
12	50018	1	Hose, fuel - .312 ID 50 psi SAE 30R7	
13	36234B	1	Bracket, fuel system	
14	60285	4	Nut, .312-18 hex, G2	
15	60393	1	Screw, .250-20 x 1.00 standard hex, G5	
16	60223	1	Screw, M6-1.00 x 20 standard hex, G4.8	
17	60286	4	Washer, .250 split lock	
18	13515	1	Element, fuel filter	
19	13481	1	Assembly, fuel filter	includes 13515
20	62001	2	Screw, .312-18 x 1.250 standard hex, G5	
21	A0001492951	1	Hose, fuel - .312 ID 50 psi SAE 30R7	
22	10775	1	Filter, oil	
23	60281	2	Screw, .250-20 x .750 standard hex, G5	
24	60026	2	Washer, M10 split lock	
25	60422	2	Screw, M10-1.25 x 25 standard hex, G8.8	
26	16589	1	Hose, air cleaner	
27	10434	1	Hose, air intake	

### *Battery Disconnect (If equipped):*

A	65499	1	Switch lockout lever kit
B	10000008538	1	Bracket, battery disconnect
C	65498	1	Switch, disconnect

**Note:** Engine and generator parts used in all Generac Mobile Products, LLC equipment carry the Original Equipment Manufacturer (OEM) warranty unless otherwise stated. OEM warranty parts must be purchased through an OEM dealer. Please contact Generac Mobile Products, LLC with questions.

# GENERATOR ASSEMBLY

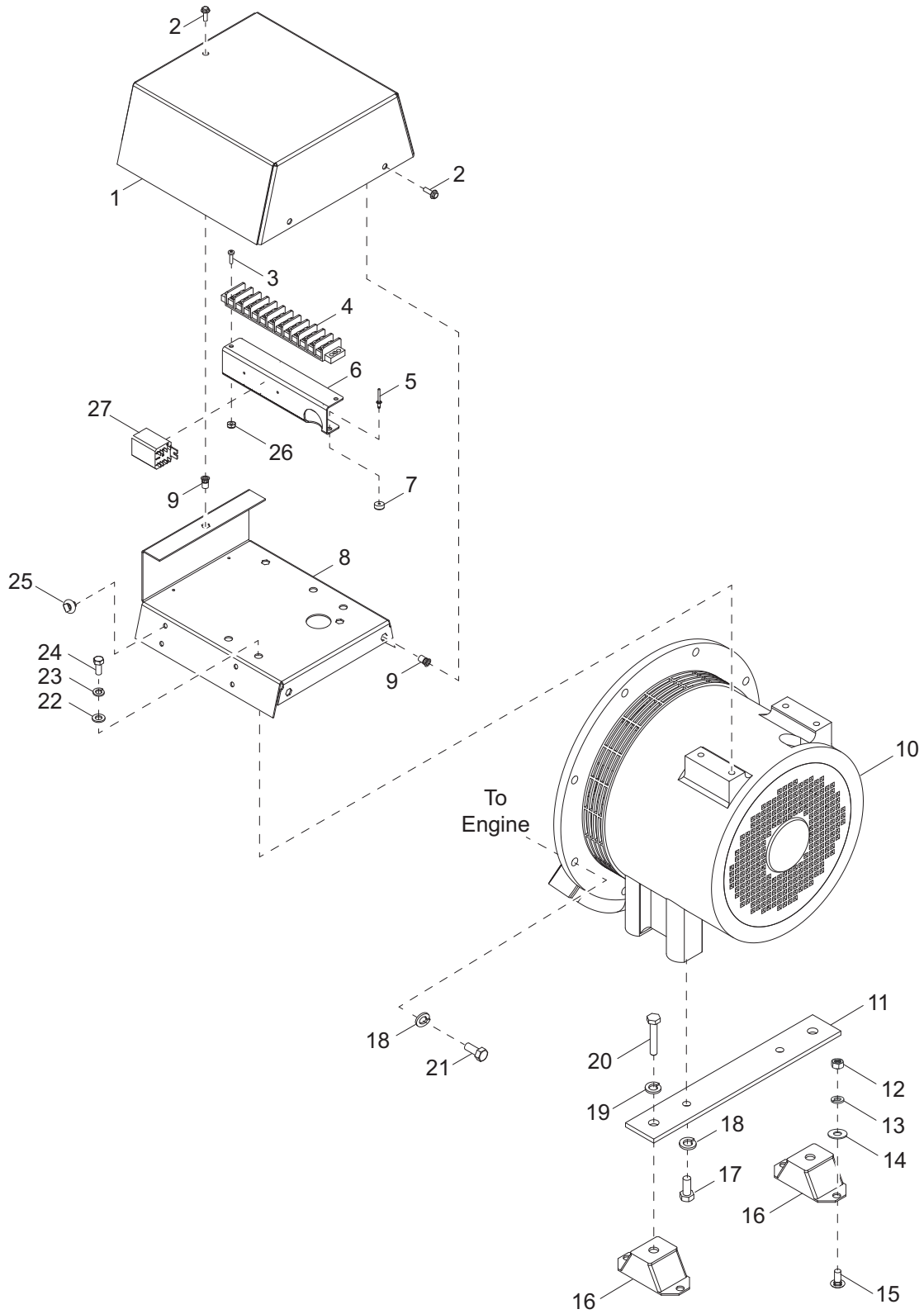

02683

## GENERATOR ASSEMBLY

Item	Part No.	Qty	Description	Notes
1	17994B	1	Cover, generator, Marathon	
2	60175	4	Screw, .250-20x.500 serrated flange hex, G5	
3	60062	2	Screw, 10-32 x .750 pan Phillips, G2	
4	14139	1	Block terminal - 12 position	
5	60267	2	Rivet, .125 diameter x .191 to .270 grip	
6	10000034474	1	Bracket, terminal strip	
7	15215	2	Rubber bumper	
8	54254B	1	Plate, electric junction	
9	63231	9	Insert, threaded .250-20 hex .027-.165 grip	
10	10000020581	1	Generator, Marathon, 6kW, 60Hz, cap	
11	15045B	1	Bracket, generator mounting	with 16556
12	60285	4	Nut, .312-18 hex, G2	
13	60271	4	Washer, .312 split lock	
14	60119	4	Washer, .312 flat .875/.070	
15	61066	4	Screw, .312-18 x 1.00 carriage, SS	
16	15241	2	Isolator, rubber - 80-200 lb	
17	60352	2	Screw, .375-16 x 1.250 standard hex, G5	
18	60206	10	Washer, .375 split lock	
19	60702	2	Washer, .500 split lock, SS	
20	60275	2	Screw, .500-13 x 1.00 standard hex, G5	
21	60352	8	Screw, .375-16x1.250 standard hex, G5	
22	60243	4	Washer, .250 flat .735/.060	
23	60271	4	Washer, .312 split lock	
24	61082	4	Screw, M8-1.25 x 20 serrated flange hex	
25	66685	8	Mount cable tie, .25-.28 diameter,.031-.276 grip	
26	60061	2	Nut, 10-32 nylock	
27	G061554	1	Relay	
--	60168	6	Screw, .312-18 x .750 standard hex, G5	For flex plate mount
--	60166	18	Washer, M8 flat DIN 125 hardened	3 each w/60168

**Note:** Engine and generator parts used in all Generac Mobile Products, LLC equipment carry the Original Equipment Manufacturer (OEM) warranty unless otherwise stated. OEM warranty parts must be purchased through an OEM dealer. Please contact Generac Mobile Products, LLC with questions.

# COMPONENTS TO TRAILER ASSEMBLY

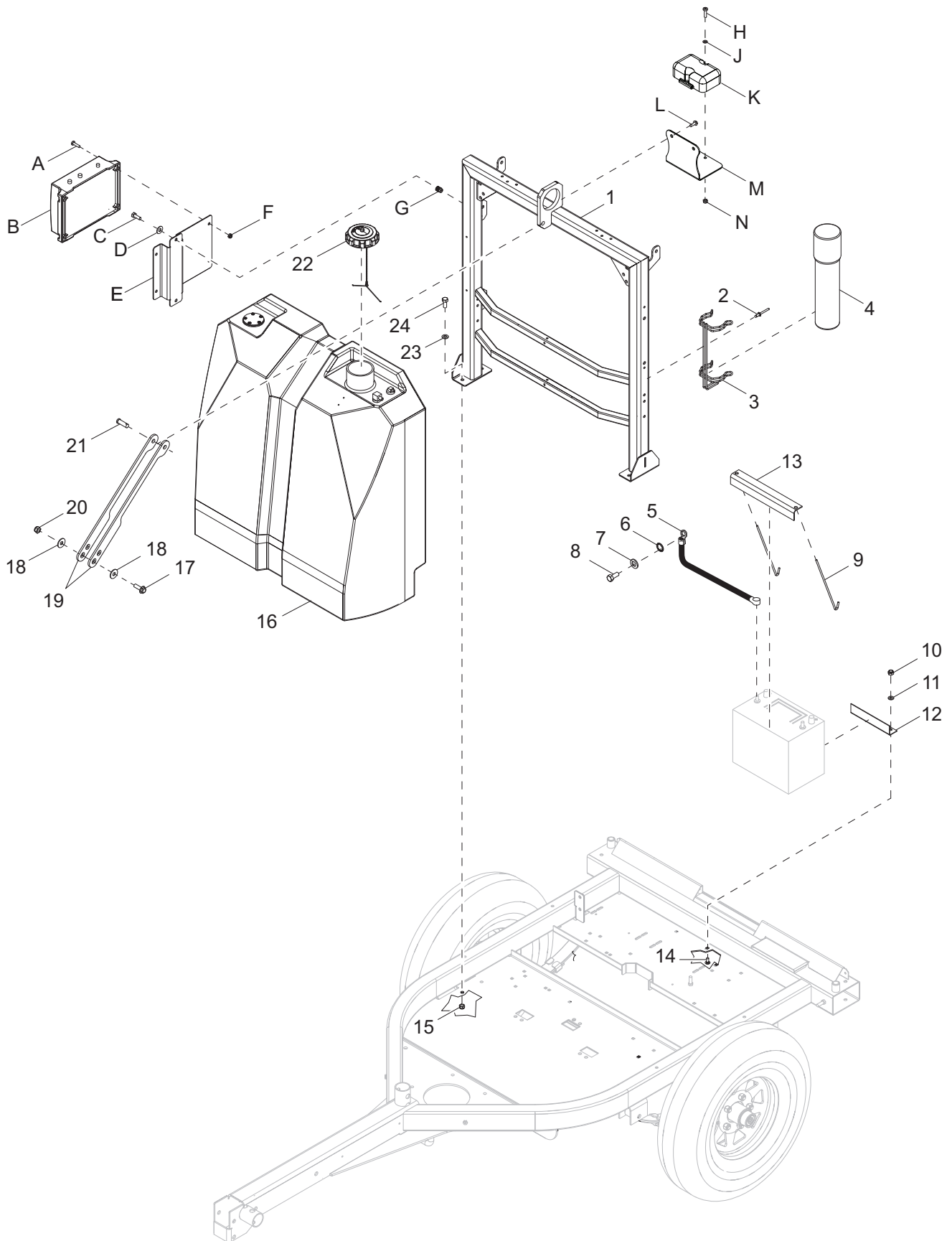

02684

## COMPONENTS TO TRAILER ASSEMBLY

Item	Part No.	Qty	Description	Notes
1	10000023283	1	Weldment, lift support	
2	60195	2	Rivet, .188 diameter. x .375 to .500 grip	
3	11222	1	Bracket, manual holder	
4	11121	1	Manual holder tube, black 14 in	
5	10699	1	Cable, battery - 24" 4GA , .375 lug, black	
6	60747	1	Washer, .375 internal star	
7	60026	1	Washer, M10 split lock	
8	60495	1	Screw, M10-1.25 x 16 hex, G8.8	
9	60820	2	Bolt, J - .250-20 x 9.0	
10	60303	1	Nut, .312-18 nylock, G2	
11	60119	2	Washer, .312 flat .875/.070	
12	17992B	1	Bracket, battery stop	
13	12924B	1	Angle, battery hold-down	
14	61066	2	Screw, .312-18 x 1.00 carriage, SS	
15	62086	6	Nut, .312-18 U-clip - short type	
16	69919	1	Tank, fuel - 42 gal w/sending unit	
17	60484	2	Screw, .500-13 x 2.00 standard hex, G5	
18	60309	4	Washer, .500 flat 1.060/.090	
19	39660B	2	Bar, chassis support	
20	62221	2	Nut, .500-13 nylock, G5	
21	63325	1	Pin, clevis - .500 diameter. x 1.063 UL, ZP	
22	16326	1	Cap, fuel, 3.5 diameter., diesel, vent w/tether	
23	60386	4	Washer, .375 flat .993-.064	
24	60352	4	Screw, .375-16 x 1.250 standard hex, G5	

*Battery Charger (If equipped):*

A	60062	4	Screw, 10-32 x .750 pan Phillips, G2
B	66212	1	Charger, battery 2-5A/1-10A, 3 stage, 2 output
C	60281	2	Screw, .250-20 x .750 hex, G5
D	60243	2	Washer, .250 flat .735/.060
E	73218B	1	Bracket, battery charger
F	60415	4	Nut, 10-32 nylock
G	63132	2	Insert, .250-20 splined, .027-.165

*ZTR Telemetry (If equipped):*

H	60770	2	Screw, M4-0.70 x 20 pan Phillips, G4.8
J	60237	2	Washer, #10 flat .495/.036
K	37731	1	Telemetry, ZTR
L	68429	2	Screw, .312-18 x .750 flange hex, G2 self-tap
M	51002B	1	Bracket, ZTR mounting
N	60051	2	Nut, M4-0.70 nylock, G8.8
--	68431	1	Lift support (modified 28341B)

# TRAILER ASSEMBLY

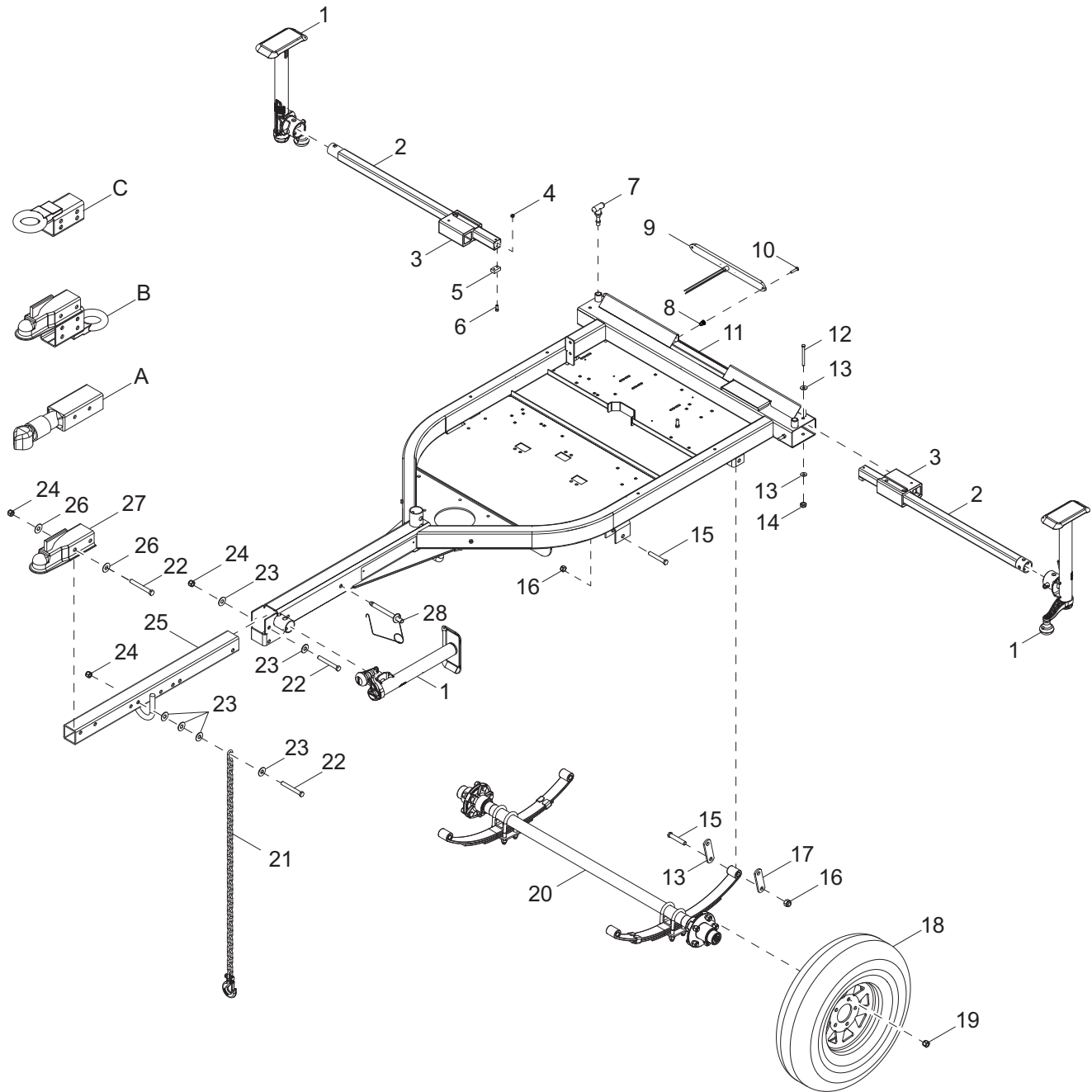

02444

## TRAILER ASSEMBLY

Item	Part No.	Qty	Description	Notes
1	72126	3	Jack, top wind - 1200 lb, tube mounted	
2	70230ZY	2	Weldment, outrigger tube	
3	36869	2	Guide block (molded) - outrigger	
4	60144	4	Nut, .250-20 nylock, G5	
5	72128	2	Pad/stop, wear - outrigger	
6	73196	4	Screw, .250-20 x 2.25 socket head	
7	36890	3	Spring pin, handle	
8	73092	4	Insert, #8-32 .020-.080 grip - close sealed	
9	36960	2	Assembly, tail light	
10	60694	4	Screw, 8-32 x .750 pan Phillips	
11	10000021817	1	Weldment, lt chassis	
12	60404	2	Screw, .312-18 x 4.00 standard hex, G5	
13	60119	4	Washer, .312 flat .875/.070	
14	60303	2	Nut, .312-18, nylock, G2	
15	60503	6	Screw, shackle, .562-18 x 3.00 standard hex, G5	
16	60504	6	Nut, .562-18 lock hex, G5	
17	19637	4	Plate, shackle bracket - 3.125"	
18	15976B	2	Wheel, ST175/8013 - 1360 lb	
19	60096	10	Nut, .500-20 lug, G5	
20	34760	1	Axle, 2200lb 47TC 35SC	
21	23367	2	Chain, safety - 7800 lbs rated	
22	50215	5	Screw, .500-13 x 4.00 standard hex, G5	
23	60416	10	Washer, .500 flat 1.375/.090	
24	62221	5	Nut, .500-13 nylock, G5	
25	17969B	1	Weldment, tilt tongue	
26	60309	4	Washer, .500 flat 1.060/.090	
27	16830	1	Coupler, 2.00 ball/2.50 channel	
28	33943	2	Pin, locking .500 x 3.50	
--	68348	1	Harness, trailer wiring, tandem tow	
--	68324	1	Harness, trailer enclosure front	
--	10000020727	1	Assembly, harness extension loomed	

### *Hitch Options (If equipped):*

A	13003B	1	Coupler, 2.00 ball/3.00 channel, Bulldog
B	34792ZC	1	Weldment, combination hitch - 2.50 tongue
C	16835B	1	Weldment, lunette ring 3.00 ID - 2.50 tongue
--	65464	1	Adapter, 4 pin flat to 4 pin flat x 12.00

# RECOMMENDED SPARE PARTS - ENGINE AND SERVICE KITS

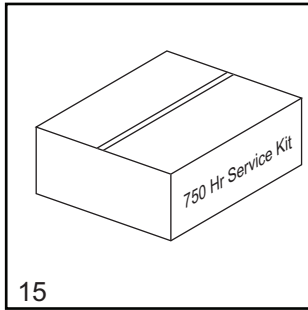
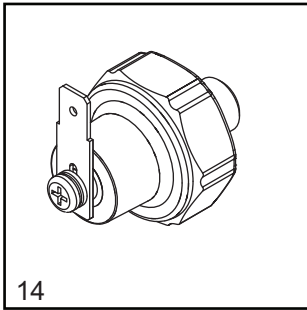
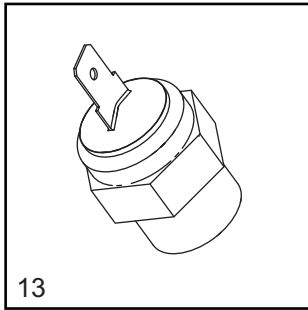
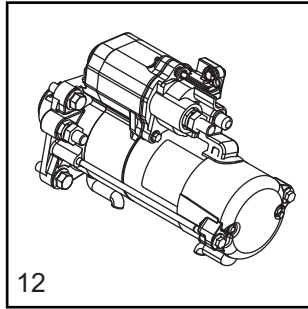
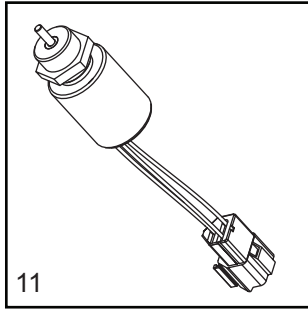
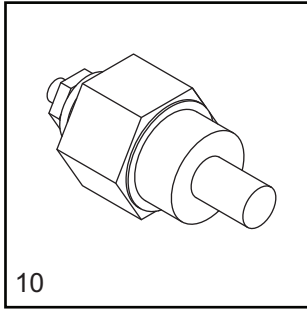
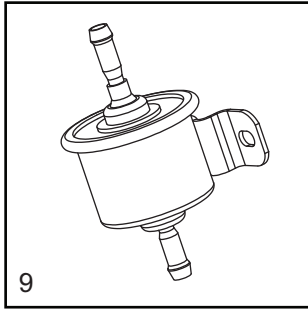
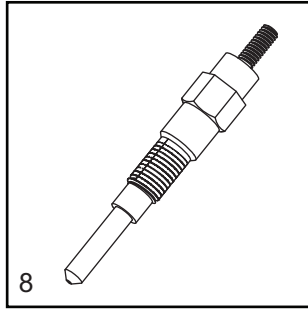
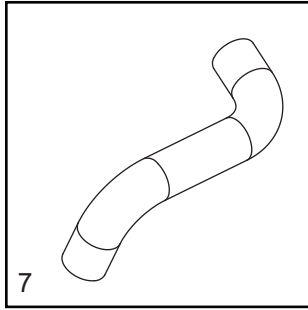
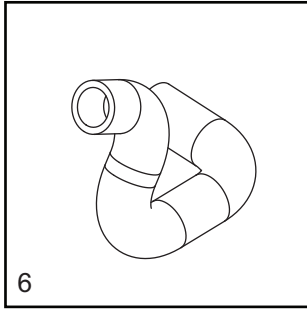
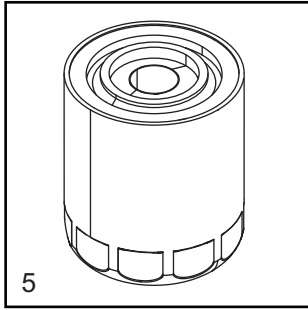
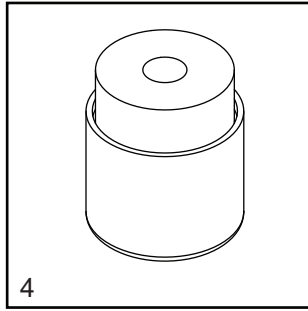
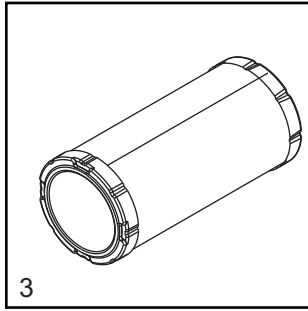
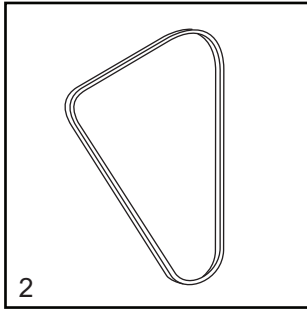
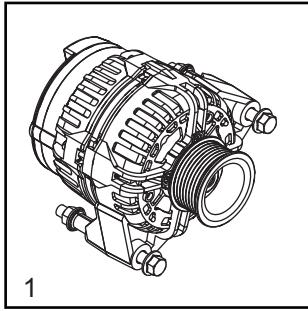



## RECOMMENDED SPARE PARTS - ENGINE AND SERVICE KITS

---

### ENGINE

1. Alternator .....	12486
2. Belt, V .....	11628
3. Filter, air (element).....	16444
4. Filter, fuel element .....	13515
5. Filter, oil, Kubota D1005/D1105 .....	10775
6. Hose, lower radiator .....	12350
7. Hose, upper radiator.....	36977
8. Plug, glow (start SN 489916).....	13238
9. Pump, fuel .....	13278SRV
10. Sender, coolant temp.....	12873
11. Solenoid, fuel shutdown (2 wire).....	13018
12. Starter- D850 .....	30582
13. Switch, coolant temperature - D850 .....	14099
14. Switch, oil pressure, D905 .....	15375

### SERVICE KITS

15. 750 hour kit.....	10000036039
-----------------------	-------------

Includes: Air Filter Element 10000035428, Fuel Filter Element 13515 and  
Oil Filter 10775

# RECOMMENDED SPARE PARTS - ELECTRICAL

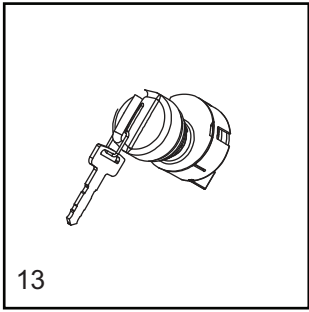
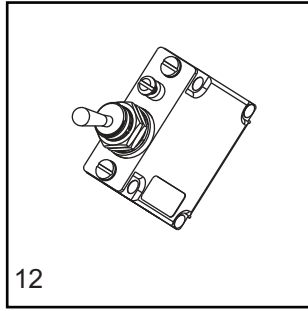
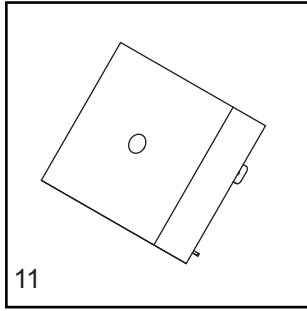
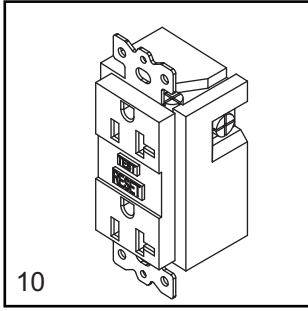
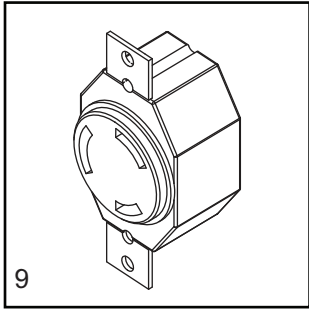
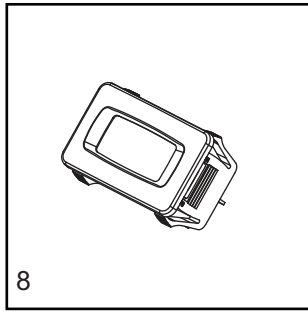
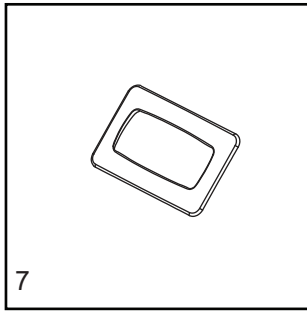
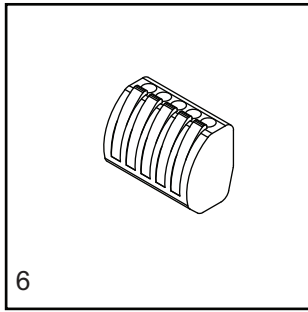
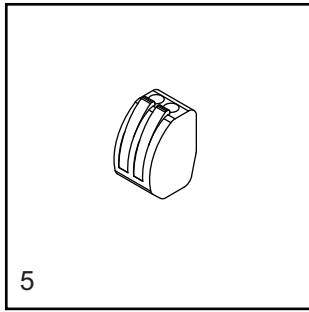
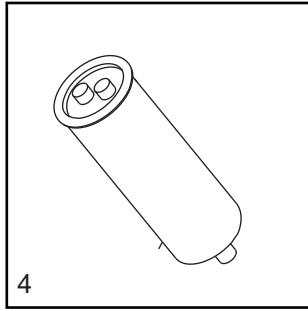
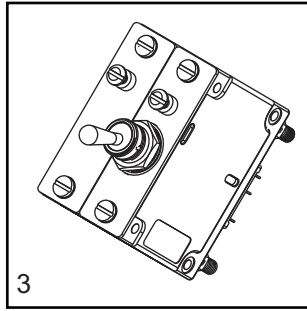
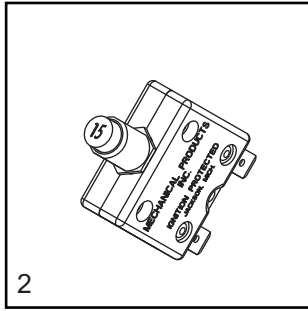
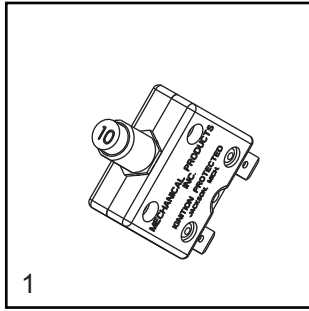

---

## RECOMMENDED SPARE PARTS - ELECTRICAL

### ELECTRICAL

1. Breaker, 10A, 240V, 1 pole, push button .....	36937
2. Breaker, 15A, 120V, 1 pole, push button, 8kW .....	36935
3. Breaker, 30A, 250A, 2 pole, 6kW .....	36975
4. Capacitor, 25 $\mu$ F 5% 440VAC .....	36980
5. Connector, 2 position (qty - 4) .....	66100
6. Connector, 5 position (qty - 2) .....	66102
7. Gasket, hour meter .....	36944
9. Gauge, hour meter .....	36886
9. Receptacle, 240V/30A twist .....	14137
10. Receptacle, 120V/20A GFI .....	14130
11. Relay, 10A SPDT 15 second time delay .....	14201
12. Switch, 10 amp .....	10000035999
13. Switch, key .....	36882

# RECOMMENDED SPARE PARTS - MISC

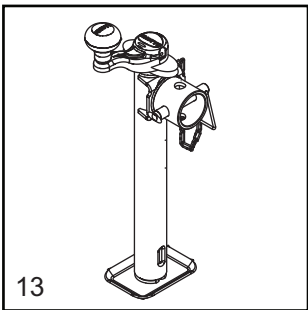
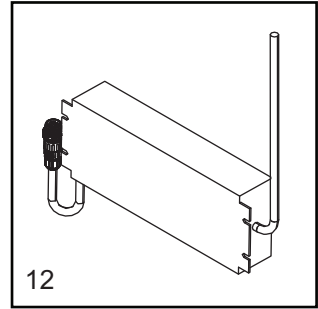
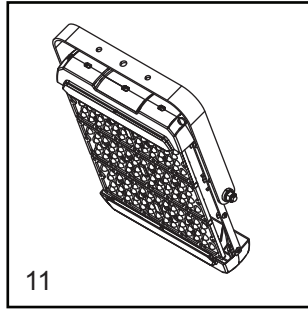
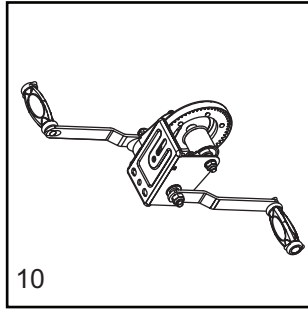
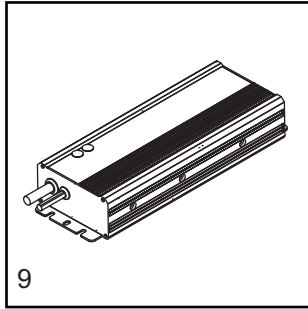
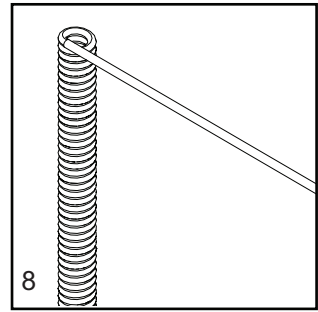
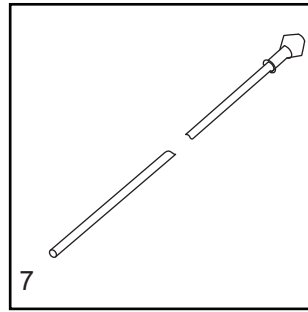
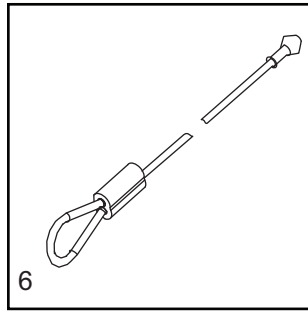
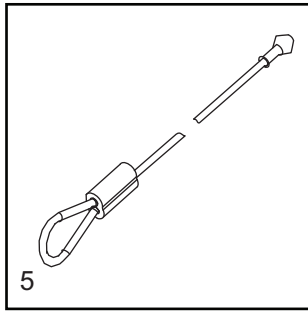
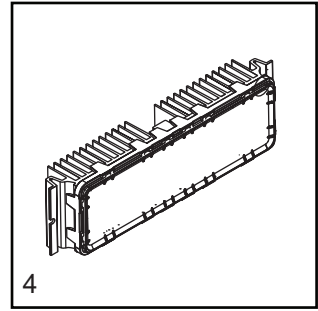
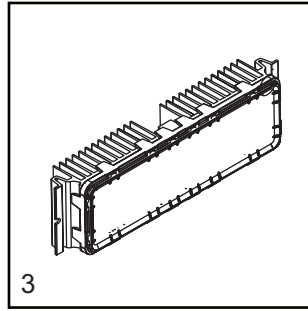
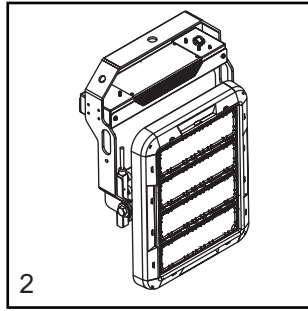
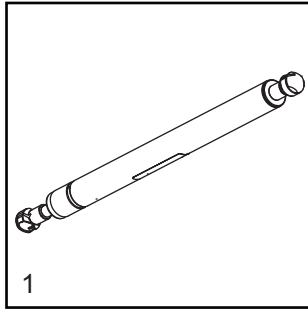

**ENCLOSURE**

1. Gas shock..... 35137

**MAST**

2. Assembly, LED light..... Call  
3. Module 60 degree LED..... 10000019170  
4. Module 40 degree LED..... 10000019160  
5. Cable, 79.75 in ..... 31248  
6. Cable, 78 in ..... 31277  
7. Cable, 144 in ..... 31247  
8. Coil cord w/ 155 inch tail (mast junction box to control box)..... A0000108466  
9. Driver, LED 30V, 10.7A, 321W ..... 72178  
10. Winch, manual, includes dual handle ..... 72127  
11. Assembly, LED light 320W - hard wire..... A0001904532  
12. Assembly, driver with connector ..... A0000188779

**JACKS**

13. Jack, top wind, 1200 lb..... 72126

This Page Intentionally Left Blank



Part No. 10000034707 Rev. F 08/18/2022

©2022 Generac Power Systems, Inc.

All rights reserved.

Specifications are subject to change without notice.

No reproduction allowed in any form without prior written consent from Generac Power Systems, Inc.



Generac Power Systems, Inc.

S45 W29290 Hwy. 59, Waukesha WI 53189

[GeneracMobileProducts.com](http://GeneracMobileProducts.com) | 844-ASK-GNRC | 844-275-4672